

Dimensions

Content

	Page
3.1 General measurement correlation	472 - 475
3.2 1-leaf door sets	476 - 477
3.3 2-leaf door sets	478 - 484
3.4 Door sets with top panel	485 - 487
3.5 Aperture angle of doors	488 - 491
3.6 Minimum LD-width	492 - 493
3.7 Opening directions	494
3.8 Dimensional measurement form	495 - 496

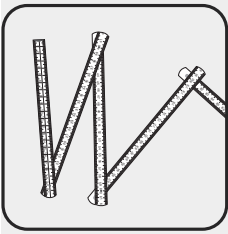

Dimensions

3.1

General measurement correlation

Wall openings according to DIN 18 100

Wall openings are subject to tolerances. Therefore an imaginary measure for structural elements, the basic dimension, was introduced. The resulting dependencies are regulated in DIN 18100 (wall opening for doors).

Wall openings are ideal if they exceed the basic dimension about 10 mm (2 x 5 mm) in width and 5 mm in height.

The construction joint, which results from the tolerances between wall opening and frame has to be bridged at installation. Especially at doors with Fire- and Smoke-Protection function as well as doors with Sound-Insulation function the joint can alter the door function. Therefore the maximum permitted construction joint size for Schörghuber Fire-Protection-Doors is $10 \pm \frac{20}{4}$ mm.

Wooden special doors

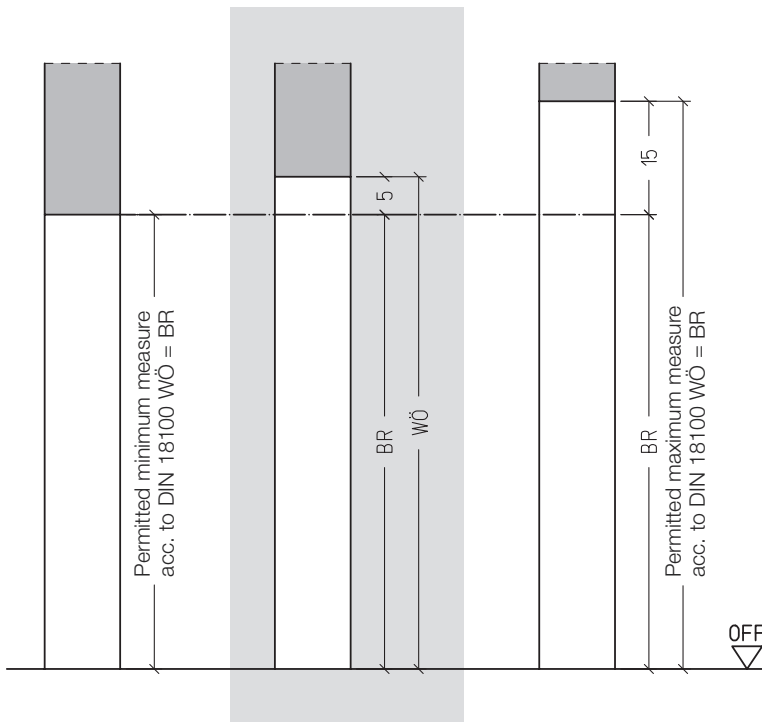

Ideal dimension: BR-Height + 5 mm

Example:

Wall opening WÖ 885 x 2005 mm (B x H)
Basic dimension BR 875 x 2000 mm (B x H)

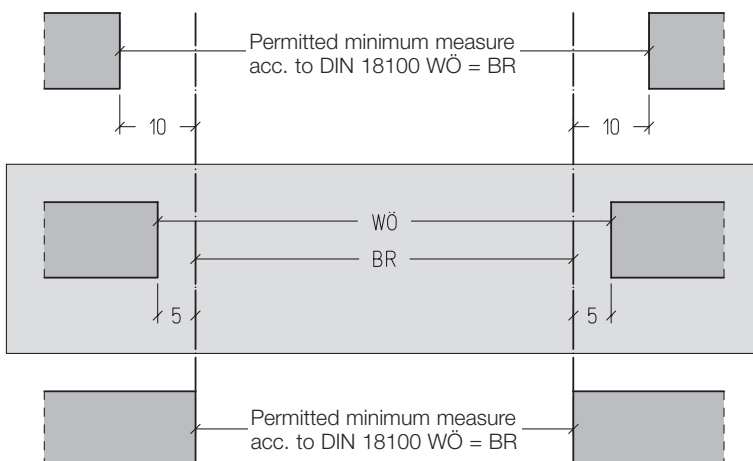

Ideal dimension: BR width + 10 mm

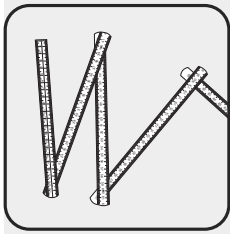

Dimensions

3.1

General measurement correlation

Measurements according to DIN 18101 and DIN 18111

Wall openings according to DIN 18100 in combination with the installation of steel wrap-around frames, quirk frames, steel corner frames and wooden wrap-around frames result in clear passages and door leaf dimensions according to DIN 18101 and DIN 18111. In order to get standard door leaf dimensions with nonstandard frames (face expansions, steel block frames, wooden block frames and solid wooden frames etc.) the wall openings need to be planed accordingly.

If wall openings are constructed according to DIN 18100, the installation of doors and frames, which have been produced according to standard, should be possible without any problems.

Wooden special doors

Steel frame

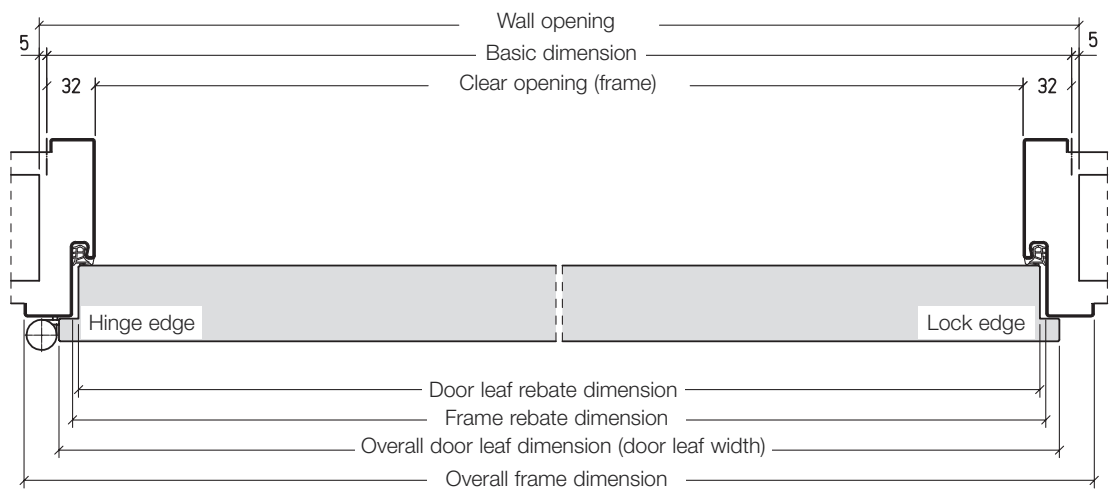

Wooden frame

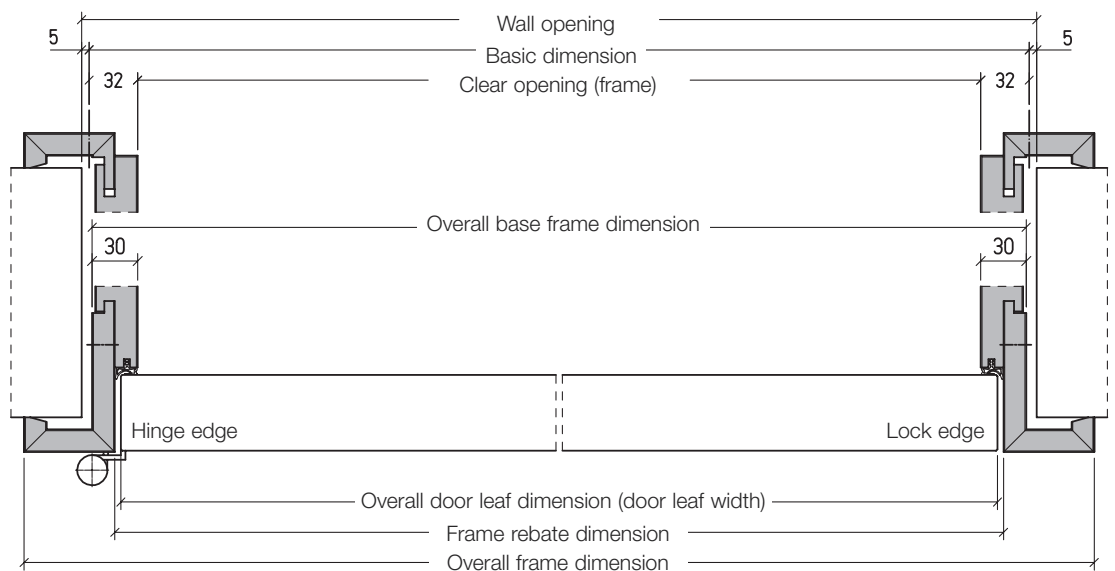

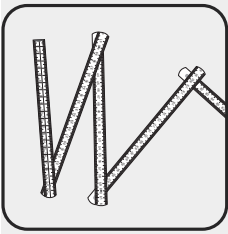

Dimensions

3.1

General measurement correlation

Measurements according to DIN 18101 and DIN 18111

Solid wooden block frame

In combination with solid wood framed door

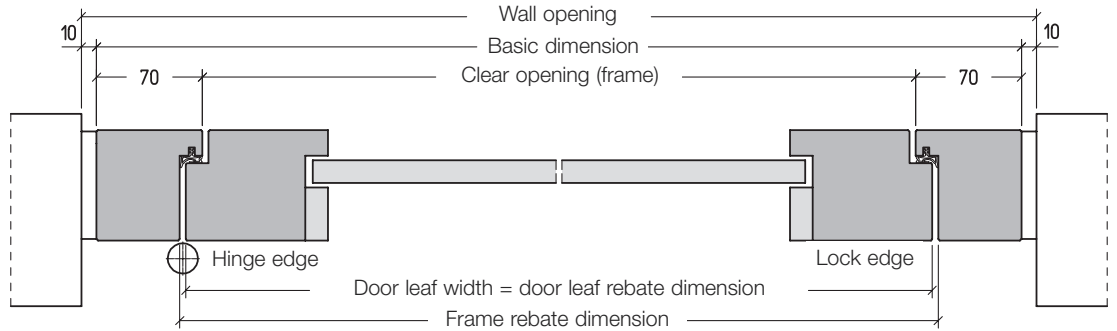

Steel frame

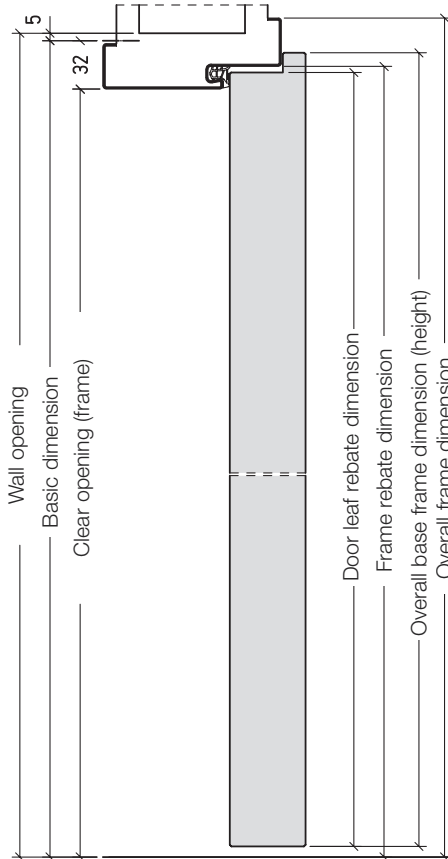

Wooden wrap-around frame

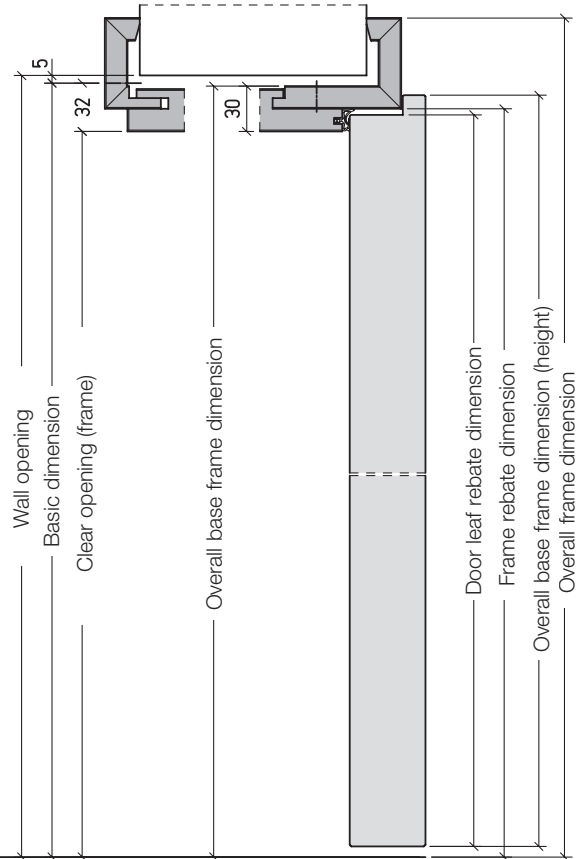

OFF

The label **OFF** indicates the nominal position of the surface of the finished floor, as for example the surface of a floor covering (carpet, flagging etc.) above screed and slab.

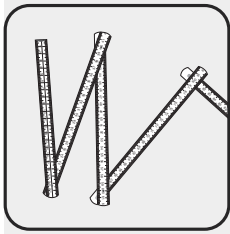

Dimensions

3.1

General measurement correlation

Overview of 1- and 2-leaf doors

Measurement correlation for **steel wrap-around frames** and **wooden wrap-around frames**

1-leaf doors width

WÖ	WÖ - 10 mm BR	BR - 34 mm ZFM	BR - 64 mm LD	LD + 48 mm TAB (F)	LD + 22 mm TAB (S)
635	625	591	561	609	583
760	750	716	686	734	708
885	875	841	811	859	833
1010	1000	966	936	984	958
1135	1125	1091	1061	1109	1083
1260	1250	1216	1186	1234	1208
1385	1375	1341	1311	1359	1333
1510	1500	1466	1436	1484	1458

Due to the joint clearance of 4 mm (instead of 3,5 mm according to DIN 68706) between door leaf and frame, the door leaf width of Schörghuber doors is 1 mm less than standard.

2-leaf doors, width, coaxial partition

WÖ	WÖ - 10 mm BR	BR - 34 mm ZFM	BR - 64 mm LD	LD + 55 mm TAB (F)	LD + 29 mm TAB (S)
1260	1250	1216	1186	621	608
1385	1375	1341	1311	683	670
1510	1500	1466	1436	746	733
1760	1750	1716	1686	871	858
2010	2000	1966	1936	996	983
2260	2250	2216	2186	1121	1108
2510	2500	2466	2436	1246	1233
2760	2750	2716	2686	1370	1357
3010	3000	2966	2936	1495	1482

The meeting stiles of the 2-leaf door types 4 N, 14 N and 24 N are rebated and equipped with a rabbet ledge. For the types 6 N, 26 N, 20 N and 27 N the meeting stiles are double-rebated: TAB (F) = LD + 68 mm, respectively TAB (S) = LD + 42 mm

Height

WÖ	WÖ - 5 mm BR	BR - 17 mm ZFM	BR - 32 mm LD	LD + 17 mm TAH (F)	LD + 4 mm TAH (S)
1755	1750	1733	1718	1735	1722
2005	2000	1983	1968	1985	1972
2130	2125	2108	2093	2110	2097
2255	2250	2233	2218	2235	2222
2505	2500	2483	2468	2485	2472
2755	2750	2733	2718	2735	2722
3005	3000	2983	2968	2985	2972
3505	3500	3483	3468	3485	3472
3755	3750	3733	3718	3735	3722

WÖ = Wall opening
TAB = Door leaf overall width
(F) = Rebated

BR = Basic dimension
TAH = Door leaf overall height
(S) = Unrebated or unrebated with jamb rebate

LD = Clear passage

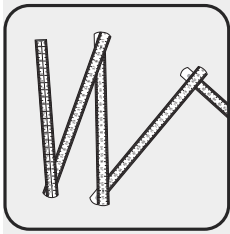

Dimensions

1-leaf door sets

Measurement correlations

Steel wrap-around frames and wooden wrap-around frames

Unrebrated or unrebrated with jamb rebate **Rebrated**
 Single rebrated frame

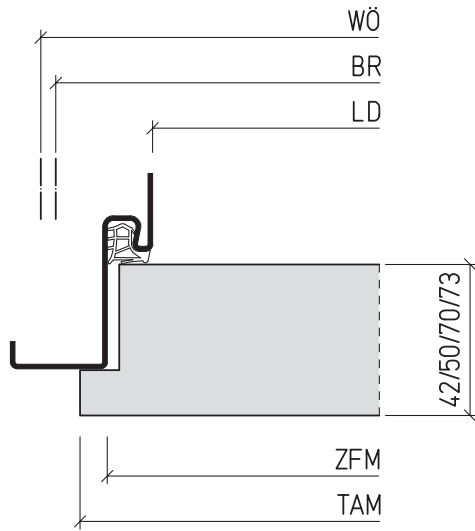

Width		Height	
BR	= WÖ - 10	BR	= WÖ - 5
LD	= BR - 64	LD	= BR - 32
ZFM	= BR - 34	ZFM	= BR - 17
TAB	= LD + 22	TAH	= LD + 4

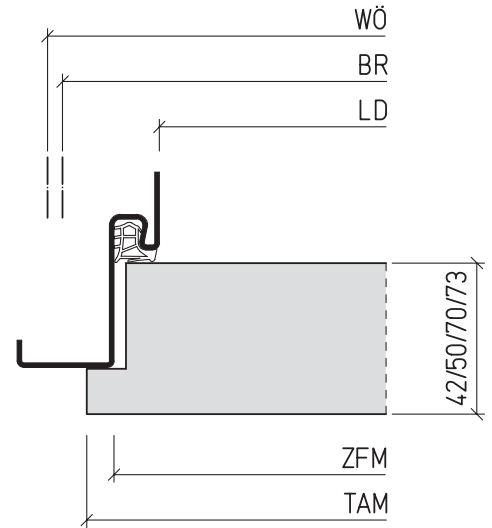

Width		Height	
BR	= WÖ - 10	BR	= WÖ - 5
LD	= BR - 64	LD	= BR - 32
ZFM	= BR - 34	ZFM	= BR - 17
TAB	= LD + 48	TAH	= LD + 17

Model 25 N Slimline

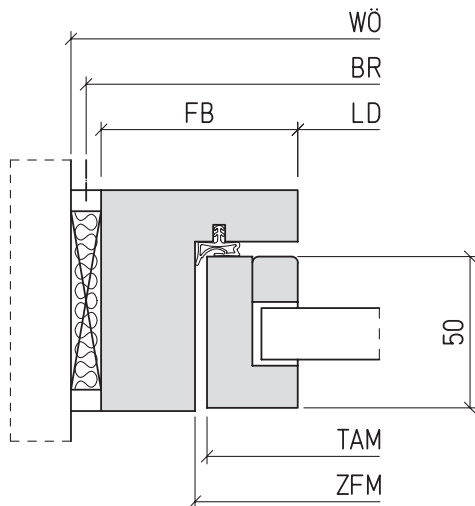

Width		Height	
BR	= WÖ - 10	BR	= WÖ - 5
LD	= BR - 10 - 2 x FB	LD	= BR - 15 - FB
ZFM	= LD + 68	ZFM	= LD + 34
TAB	= LD + 68	TAH	= LD + 23

Due to the joint clearance of 4 mm (instead of 3,5 mm according to DIN 68706) between door leaf and frame, the door leaf width of Schörghuber doors is 1 mm less than standard.

- WÖ = Wall opening
- BR = Basic dimension
- LD = Clear passage
- TAB = Door leaf overall width
- TAH = Door leaf overall height

Wooden special doors

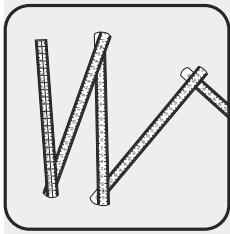

Dimensions

3.2

1-leaf door sets

Measurement correlations

Steel wrap-around frames and wooden wrap-around frames

Unrebrated with jamb rebate

Double-rebated frame

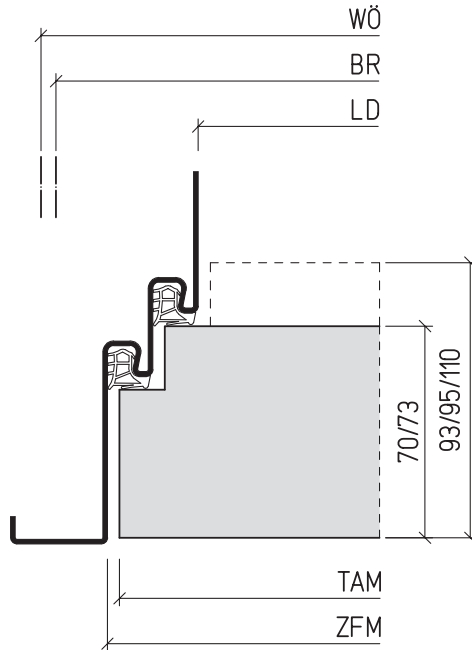

Width	Height
BR = WÖ - 10	BR = WÖ - 5
LD = BR - 94	LD = BR - 47
ZFM = BR - 34	ZFM = BR - 17
TAB = LD + 52	TAH = LD + 19

Double-rebated

Single rebated frame

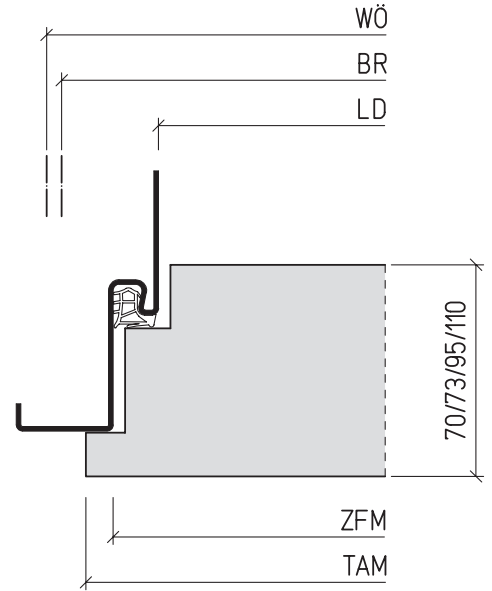

Width	Height
BR = WÖ - 10	BR = WÖ - 5
LD = BR - 64	LD = BR - 32
ZFM = BR - 34	ZFM = BR - 17
TAB = LD + 48	TAH = LD + 17

Double-rebated

Double-rebated frame

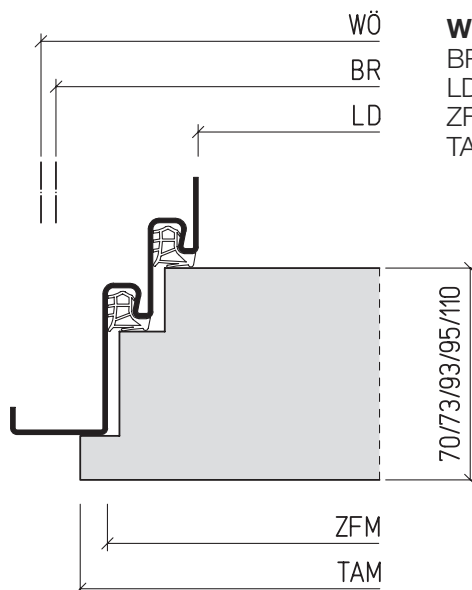

Width	Height
BR = WÖ - 10	BR = WÖ - 5
LD = BR - 94	LD = BR - 47
ZFM = BR - 34	ZFM = BR - 17
TAB = LD + 52	TAH = LD + 32

Due to the joint clearance of 4 mm (instead of 3,5 mm according to DIN 68706) between door leaf and frame, the door leaf width of Schörghuber doors is 1 mm less than standard.

WÖ = Wall opening
 BR = Basic dimension
 LD = Clear passage
 TAB = Door leaf overall width
 TAH = Door leaf overall height

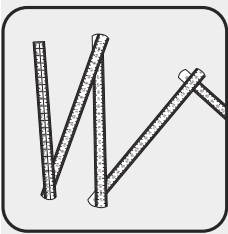

Dimensions

3.3

2-leaf door sets

Measurement correlations

Steel wrap-around frames and wooden wrap-around frames

Single rebated

Single rebated meeting stiles

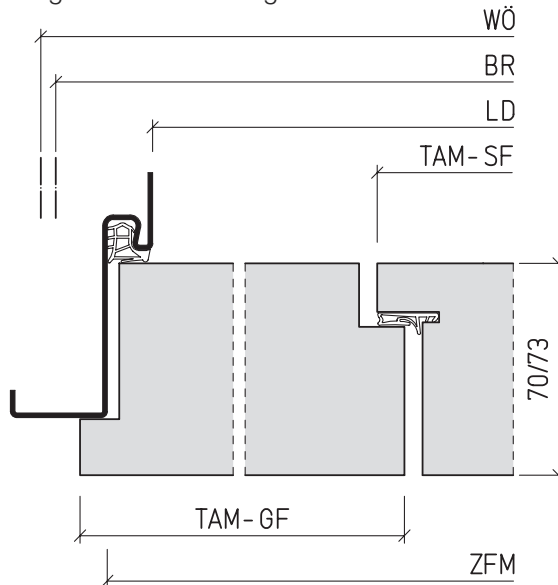

Width

$$\begin{aligned} BR &= WÖ - 10 \\ LD &= BR - 64 \\ ZFM &= BR - 34 \\ TAB &= LD + 57 \\ &\text{(coaxial partition) } 2 \end{aligned}$$

Height

$$\begin{aligned} BR &= WÖ - 5 \\ LD &= BR - 32 \\ ZFM &= BR - 17 \\ TAH &= LD + 17 \end{aligned}$$

With rabbet ledge

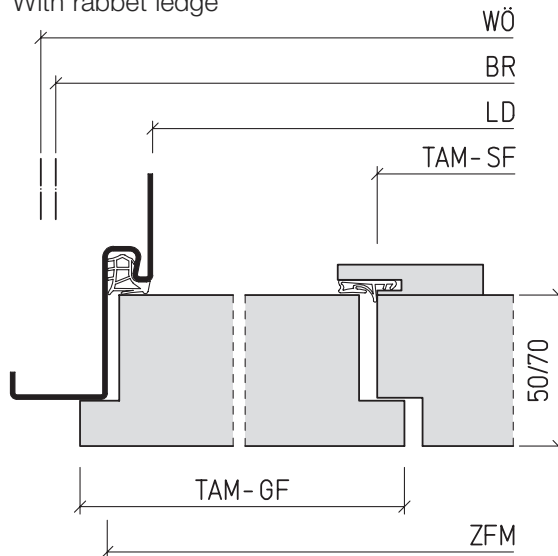

Width

$$\begin{aligned} BR &= WÖ - 10 \\ LD &= BR - 64 \\ ZFM &= BR - 34 \\ TAB &= LD + 57 \\ &\text{(coaxial partition) } 2 \end{aligned}$$

Height

$$\begin{aligned} BR &= WÖ - 5 \\ LD &= BR - 32 \\ ZFM &= BR - 17 \\ TAH &= LD + 17 \end{aligned}$$

With surface-mounted door closer

≤ 390 mm a spring hinge is required, not for Smoke-Protection-Function (door coordination via integrated IS triggering roll)

With floor-mounted door closer

≤ 445 mm a spring hinge is required, not for Smoke-Protection-Function (door coordination via SR 392)

Besides the minimum and maximum dimensions of the clear passage, the dimension limit values according to the approval and test certificate of the active and inactive leaf for 2-leaf Fire- and Smoke-Protection-Doors must be taken into account during the planning process. When designing the inactive leaf the type and the dimensions of the door closer must be considered.

Type	LD-Width	TAB-GF	TAB-SF
6 N (37 dB)	1311-2936	713-1484	528-1504
26 N	1311-2936	713-1484	528-1504
27 N	1311-2936	713-1484	528-1504
4 N	1186-2686	528-1379	313-1364
24 N	1186-2936	528-1504	513-1489

WÖ = Wall opening
BR = Basic dimension
LD = Clear passage
TAB = Door leaf overall width
TAH = Door leaf overall height
SF = Inactive leaf
GF = Active leaf

Wooden special doors



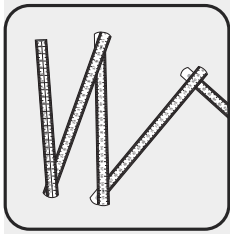

Dimensions

2-leaf door sets

Measurement correlations

Wooden special doors

Steel wrap-around frames and wooden wrap-around frames

Unrebrated or unrebrated with jamb rebate

Single rebated meeting stiles, single rebated frame

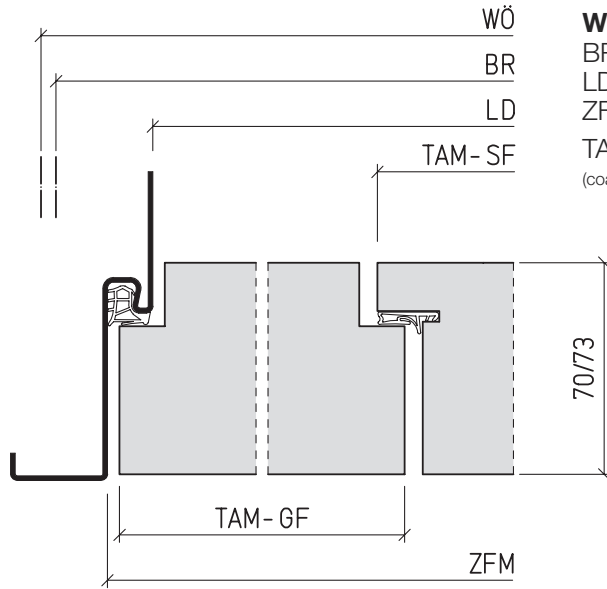

Width
 $BR = WÖ - 10$
 $LD = BR - 64$
 $ZFM = BR - 34$
 $TAB = \frac{LD + 31}{2}$
 (coaxial partition)

Height
 $BR = WÖ - 5$
 $LD = BR - 32$
 $ZFM = BR - 17$
 $TAH = LD + 4$

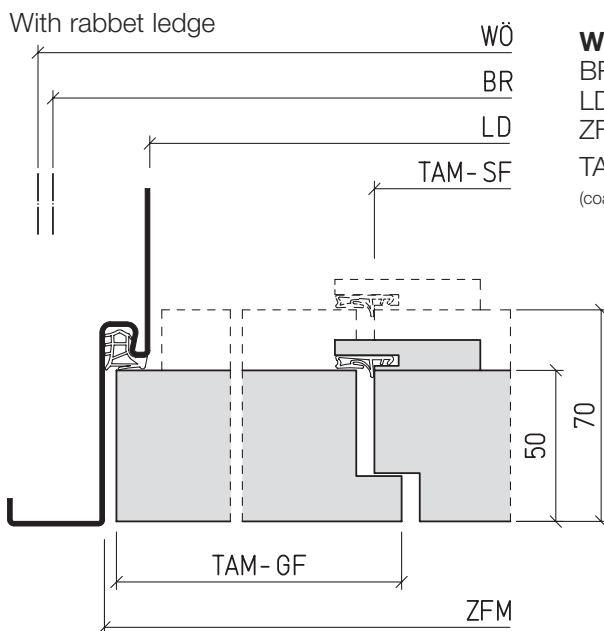

Width
 $BR = WÖ - 10$
 $LD = BR - 64$
 $ZFM = BR - 34$
 $TAB = \frac{LD + 31}{2}$
 (coaxial partition)

Height
 $BR = WÖ - 5$
 $LD = BR - 32$
 $ZFM = BR - 17$
 $TAH = LD + 4$

With surface-mounted door closer
 ≤ 390 mm a spring hinge is required, not for Smoke-Protection-Function (door coordination via integrated IS triggering roll)

With floor-mounted door closer
 ≤ 445 mm a spring hinge is required, not for Smoke-Protection-Function (door coordination via SR 392)

Besides the minimum and maximum dimensions of the clear passage, the dimension limit values according to the approval and test certificate of the active and inactive leaf for 2-leaf Fire- and Smoke-Protection-Doors must be taken into account during the planning process.

When designing the inactive leaf the type and the dimensions of the door closer must be considered.

Type	LD-Width	TAB-GF	TAB-SF
6 N (37 dB)	1311-2936	700-1476	515-1491
26 N	1311-2936	700-1476	515-1491
27 N	1311-2936	700-1476	515-1491
4 N	1186-2686	515-1366	300-1351
24 N	1186-2936	515-1491	500-1476

WÖ = Wall opening
 BR = Basic dimension
 LD = Clear passage
 TAB = Door leaf overall width
 TAH = Door leaf overall height
 SF = Inactive leaf
 GF = Active leaf

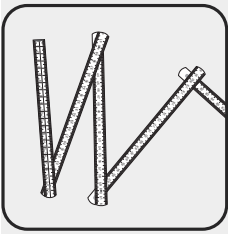

Dimensions

3.3

2-leaf door sets

Measurement correlations

Steel wrap-around frames and wooden wrap-around frames

Single rebated or double rebated

Double-rebated meeting stiles, single rebated frame

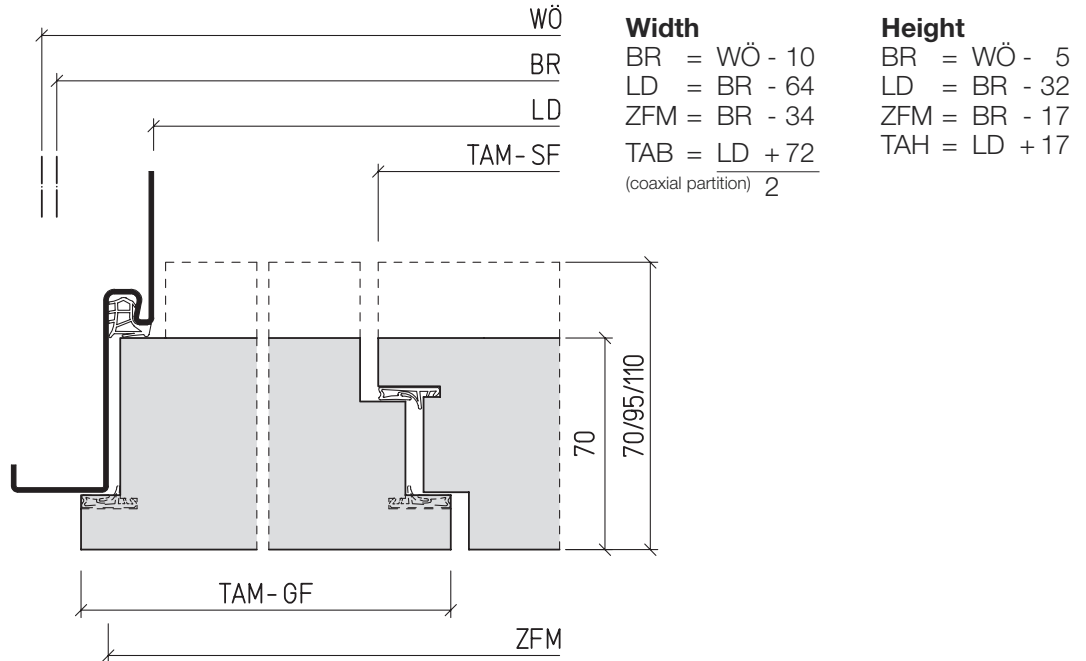

Besides the minimum and maximum dimensions of the clear passage, the dimension limit values according to the approval and test certificate of the active and inactive leaf for 2-leaf Fire- and Smoke-Protection-Doors must be taken into account during the planning process.

When designing the inactive leaf the type and the dimensions of the door closer must be considered.

Type	LD-Width	TAB-GF	TAB-SF
6 N (42 dB)	1311-2936	728-1504	528-1504
27 N (95 mm)	1311-2936	728-1504	528-1504
20 N	1311-2936	728-1504	528-1504

Wooden special doors

WÖ = Wall opening
 BR = Basic dimension
 LD = Clear passage
 TAB = Door leaf overall width
 TAH = Door leaf overall height
 SF = Inactive leaf
 GF = Active leaf

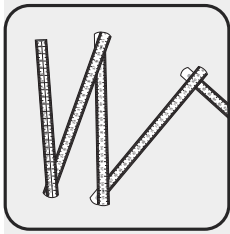

Dimensions

2-leaf door sets

Measurement correlations

Steel wrap-around frames and wooden wrap-around frames

Unrebated with jamb rebate

Double-rebated meeting stiles, single rebated frame

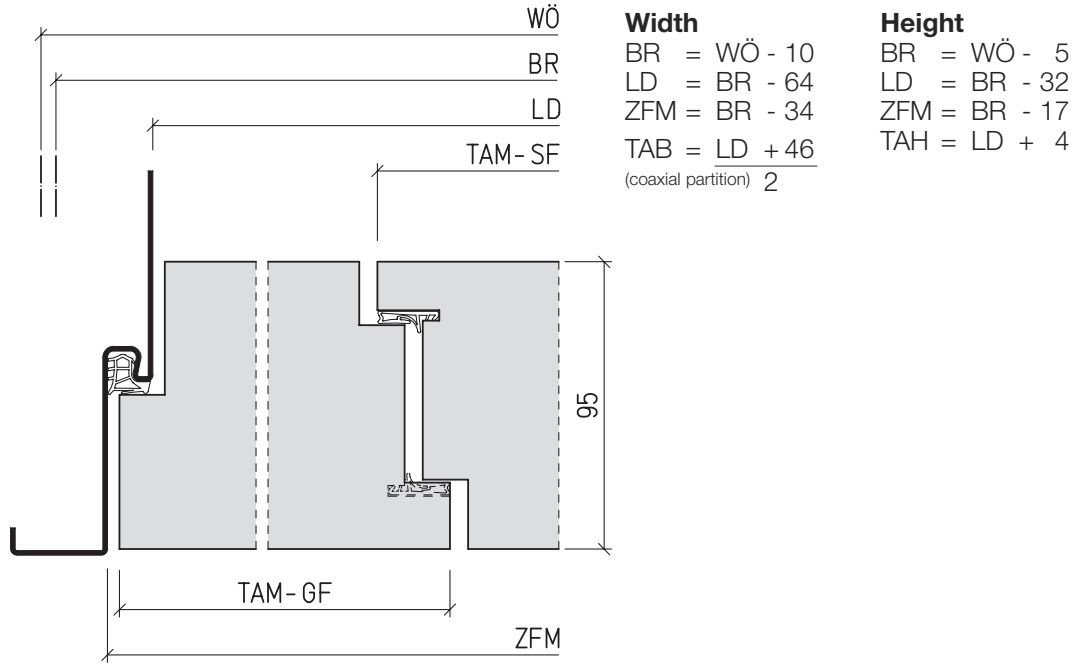

Besides the minimum and maximum dimensions of the clear passage, the dimension limit values according to the approval and test certificate of the active and inactive leaf for 2-leaf Fire- and Smoke-Protection-Doors must be taken into account during the planning process. When designing the inactive leaf the type and the dimensions of the door closer must be considered.

Type	LD-Width	TAB-GF	TAB-SF
27 N (95 mm)	1311-2936	715-1491	515-1491

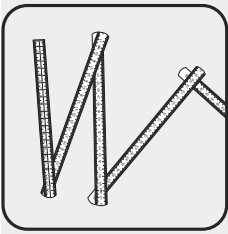

Dimensions

3.3

2-leaf door sets

Measurement correlations

Steel wrap-around frames and wooden wrap-around frames

Unrebrated with jamb rebate or unrebrated with double jamb rebate

Double-rebrated meeting stiles, double-rebrated frame

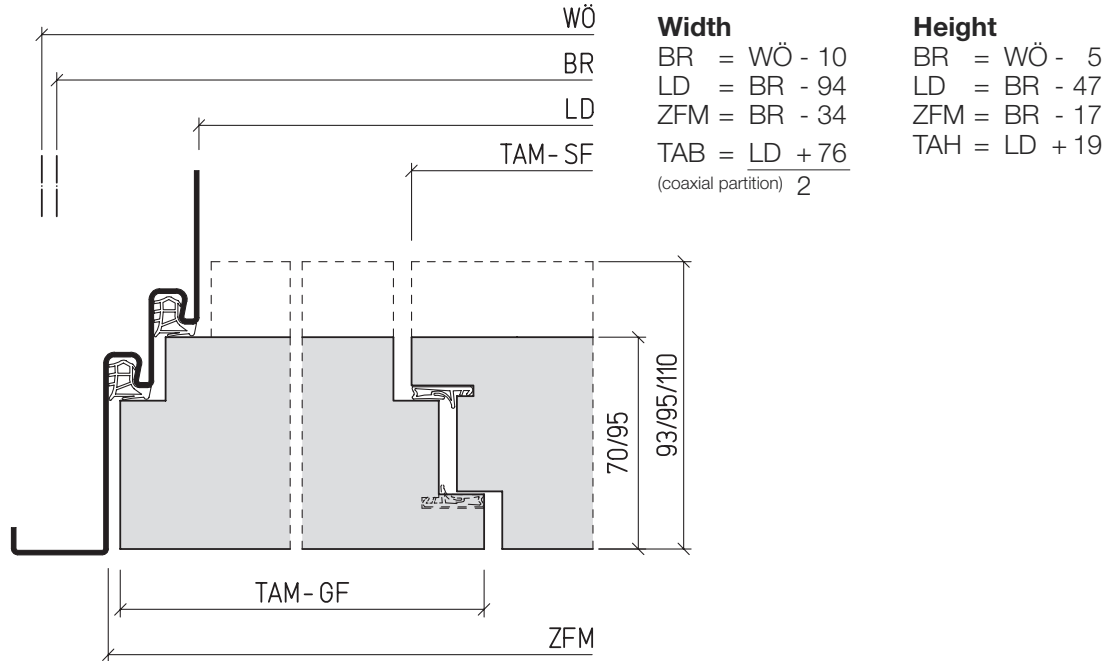

Besides the minimum and maximum dimensions of the clear passage, the dimension limit values according to the approval and test certificate of the active and inactive leaf for 2-leaf Fire- and Smoke-Protection-Doors must be taken into account during the planning process. When designing the inactive leaf the type and the dimensions of the door closer must be considered.

Type	LD-Width	TAB-GF	TAB-SF
6 N (42 dB)	1281-2906	715-1491	515-1491
27 N (95 mm)	1281-2906	715-1491	515-1491
20 N	1281-2906	715-1491	515-1491
80-2	1156-2906	515-1491	515-1491

Wooden special doors

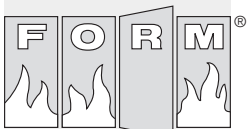

Schörghuber

WÖ = Wall opening
 BR = Basic dimension
 LD = Clear passage
 TAB = Door leaf overall width
 TAH = Door leaf overall height
 SF = Inactive leaf
 GF = Active leaf

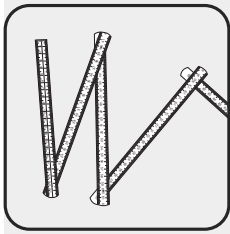

Dimensions

2-leaf door sets

Measurement correlations

Steel wrap-around frames and wooden wrap-around frames

Double-rebated

Double-rebated meeting stiles, double-rebated frame

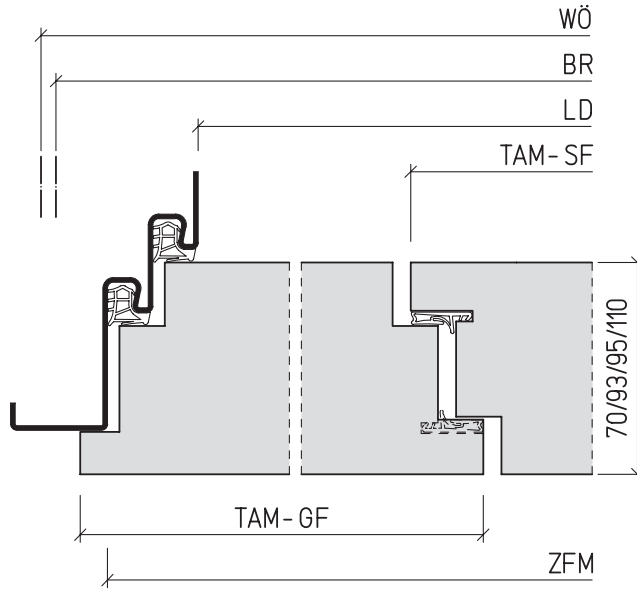

Width

BR = WÖ - 10
 LD = BR - 94
 ZFM = BR - 34
 TAB = LD + 102
 (coaxial partition) 2

Height

BR = WÖ - 5
 LD = BR - 47
 ZFM = BR - 17
 TAH = LD + 32

Besides the minimum and maximum dimensions of the clear passage, the dimension limit values according to the approval and test certificate of the active and inactive leaf for 2-leaf Fire- and Smoke-Protection-Doors must be taken into account during the planning process.

When designing the inactive leaf the type and the dimensions of the door closer must be considered.

Type	LD-Width	TAB-GF	TAB-SF
6 N (42 dB)	1281-2906	728-1504	528-1504
27 N (95 mm)	1281-2906	728-1504	528-1504
20 N	1281-2906	728-1504	528-1504
50-2	1281-2906	725-1504	528-1504
80-2	1156-2906	528-1504	528-1504

WÖ = Wall opening
 BR = Basic dimension
 LD = Clear passage
 TAB = Door leaf overall width
 TAH = Door leaf overall height
 SF = Inactive leaf
 GF = Active leaf

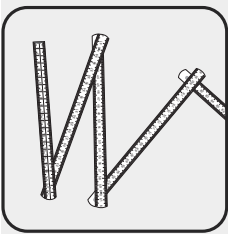

Dimensions

2-leaf door sets

Measurement correlations

3.3

3

Wooden special doors

Solid wooden frame

Unrebated with double jamb rebate

Double-rebated meeting stiles, double-rebated frame

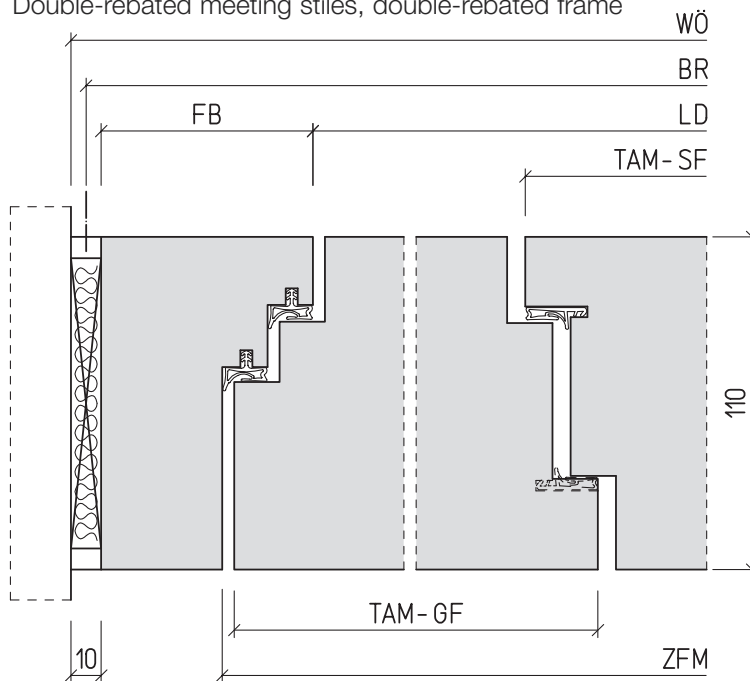

Width

$$\begin{aligned} BR &= WÖ - 10 \\ LD &= BR - 10 - 2 \times FB \\ ZFM &= LD + 60 \\ TAB &= LD + 76 \\ &\text{(coaxial partition) } 2 \end{aligned}$$

Height

$$\begin{aligned} BR &= WÖ - 5 \\ LD &= BR - 5 - FB \\ ZFM &= LD + 30 \\ TAH &= LD + 19 \end{aligned}$$

Model 27 N Slimline

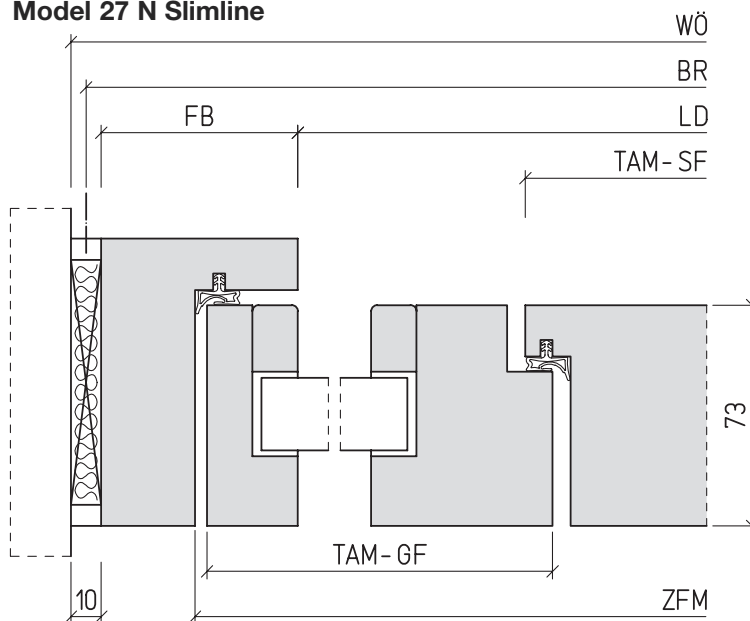

Width

$$\begin{aligned} BR &= WÖ - 10 \\ LD &= BR - 10 - 2 \times FB \\ ZFM &= LD + 68 \\ TAB &= LD + 69 \\ &\text{(coaxial partition) } 2 \end{aligned}$$

Height

$$\begin{aligned} BR &= WÖ - 5 \\ LD &= BR - 5 - FB \\ ZFM &= LD + 34 \\ TAH &= LD + 23 \end{aligned}$$

Besides the minimum and maximum dimensions of the clear passage, the dimension limit values according to the approval and test certificate of the active and inactive leaf for 2-leaf Fire- and Smoke-Protection-Doors must be taken into account during the planning process.

When designing the inactive leaf the type and the dimensions of the door closer must be considered.

- WÖ = Wall opening
- BR = Basic dimension
- LD = Clear passage
- TAB = Door leaf overall width
- TAH = Door leaf overall height
- SF = Inactive leaf
- GF = Active leaf

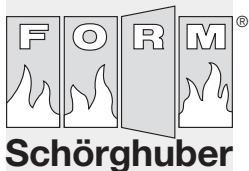

Type	LD-Width	TAB-GF	TAB-SF
92 N	1281-2406	715-1287	515-1287
25 Slimline	1148-2398	700-1233	500-1233

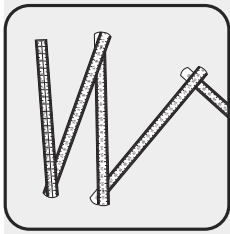

Dimensions

3.4

Door sets with top panel

Counter rebated top panel

Rebated, analogue for unrebated door leaves

3 N/4 N, 13 N/14 N

16 N/26 N, 5 N/ 6 N
25 N/27 N, 10 N/20 N

8 N/24 N

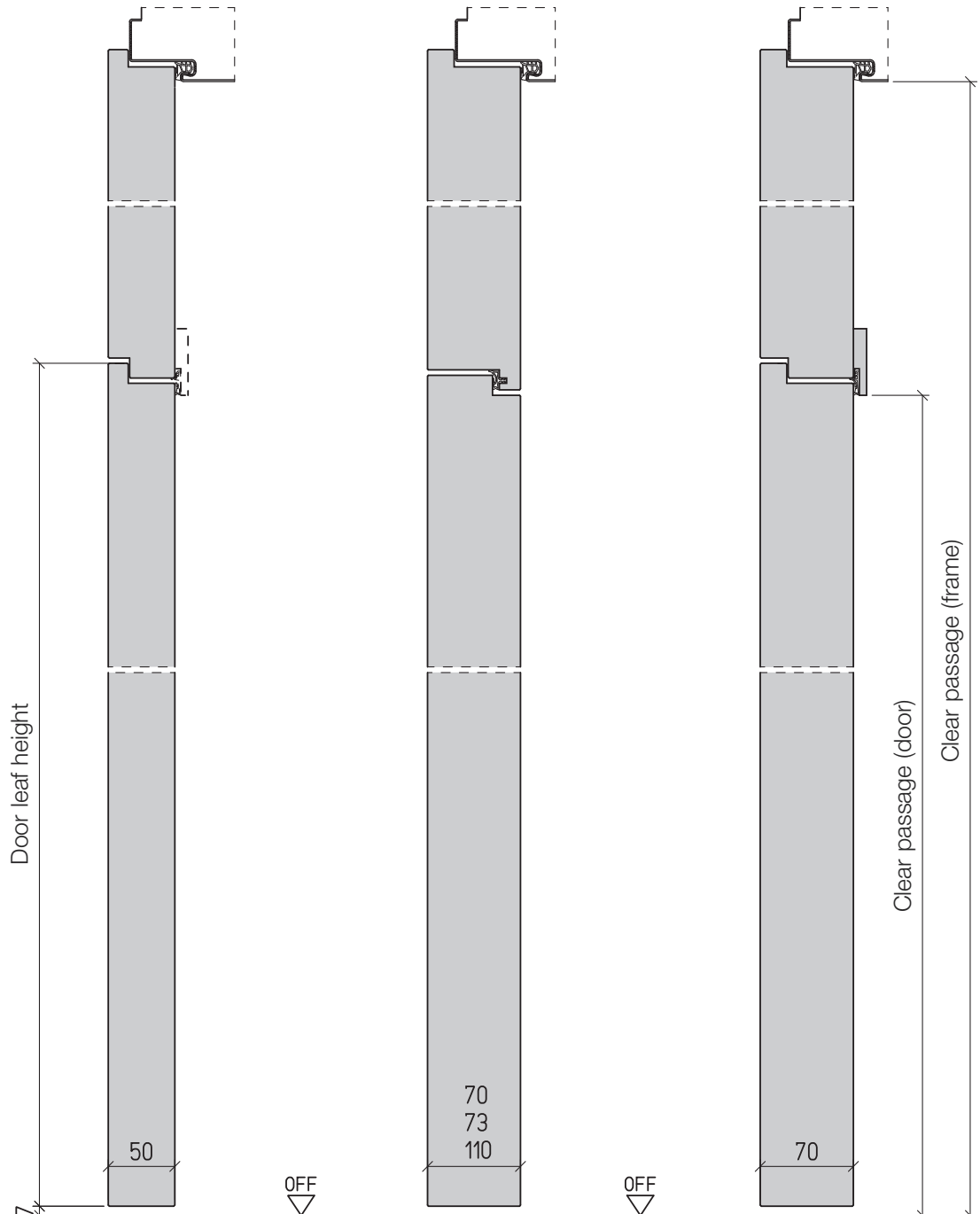

Thickness of door leaf 50 mm

1-leaf door

in combination with OTS DORMA ITS 96 with rabbet ledge

2-leaf door

generally with rabbet ledge

In order to determine or tender 1- and 2-leaf door sets with top panel, the indication not only of the clear opening of the frame or of the basic dimension is necessary, but also the information about the door leaf height.

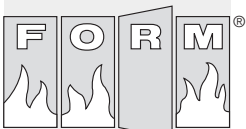

Schörghuber

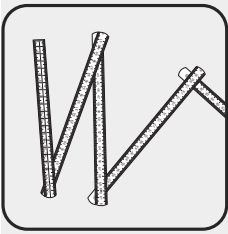

Dimensions

3.4

Door sets with top panel

Top panel with transom

Wooden special doors

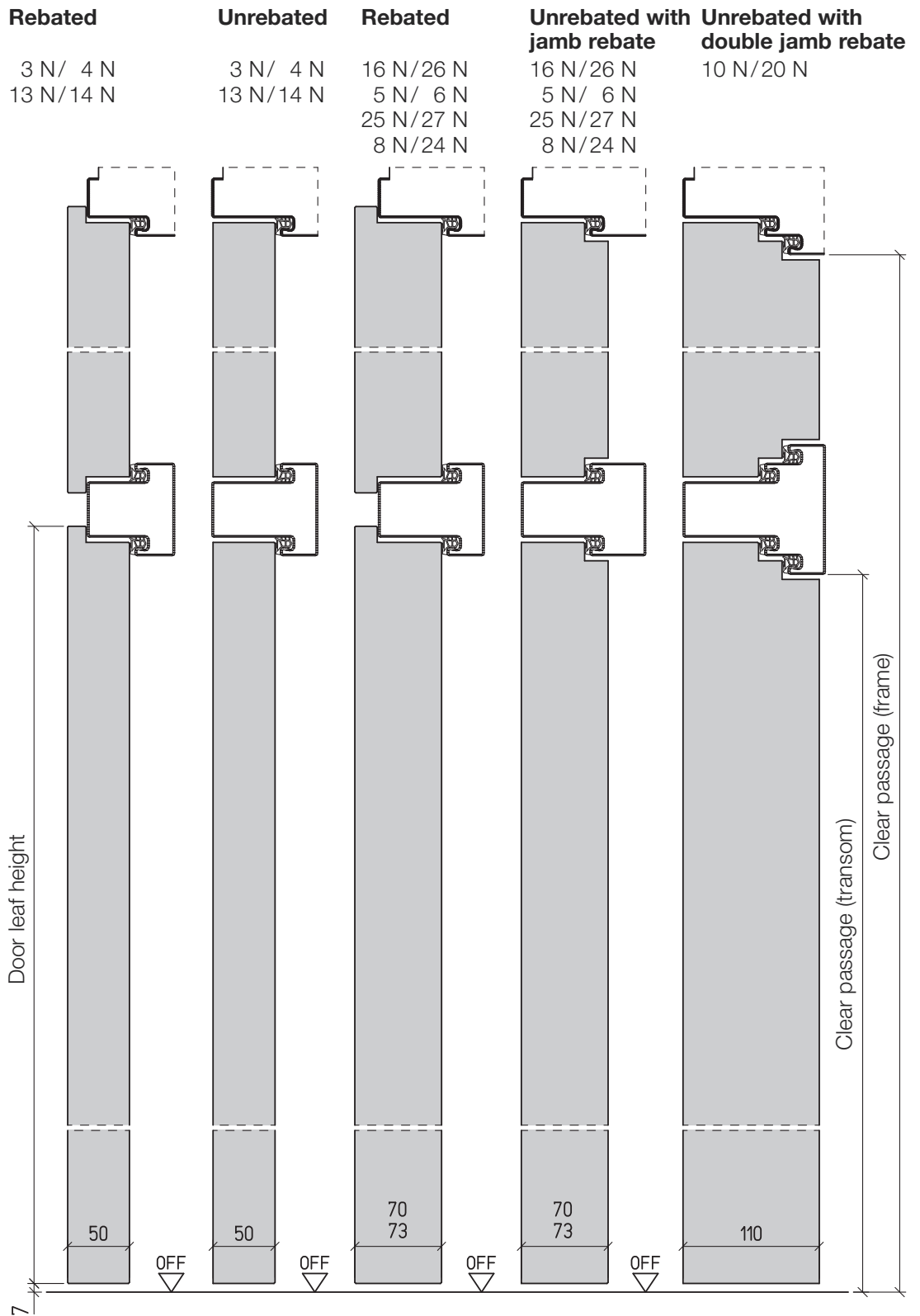

In order to determine or tender 1- and 2-leaf door sets with top panel, the indication not only of the clear opening of the frame or of the basic dimension is necessary, but also the information about the door leaf height.



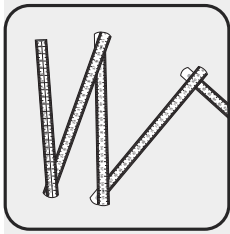

Dimensions

3.4

Door sets with top panel

Fanlight with transom

Rebated, analogue for unrebated door leaves

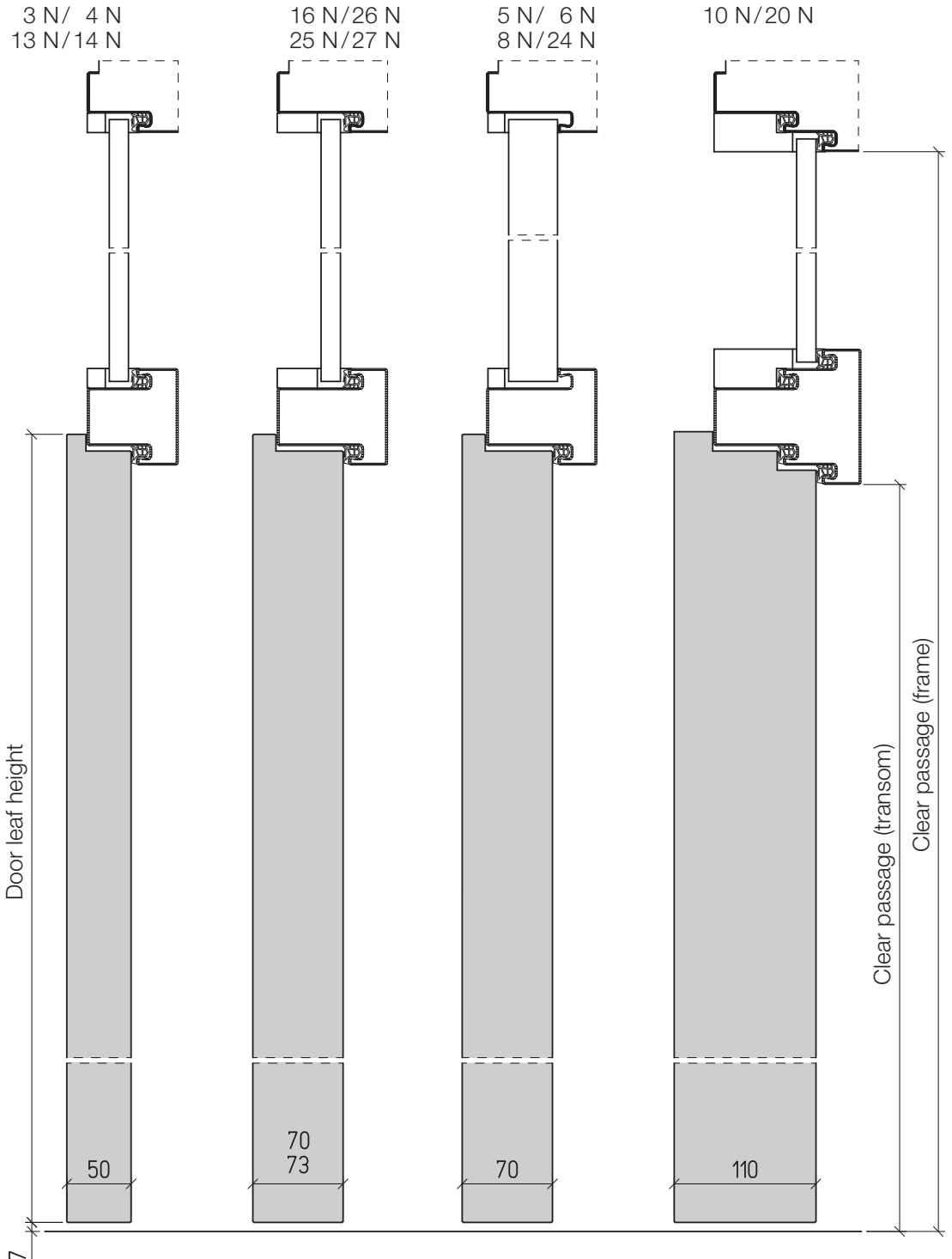

In order to determine or tender 1- and 2-leaf door sets with top panel, the indication not only of the clear opening of the frame or of the basic dimension is necessary, but also the information about the door leaf height.

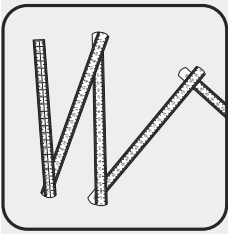

Dimensions

3.5

Aperture angle of doors

Required frame width for a 90° aperture angle

Surface-mounted door closer with hinges

Valid for all frame versions

Rebated door leaf

Thickness of door leaf 50 mm

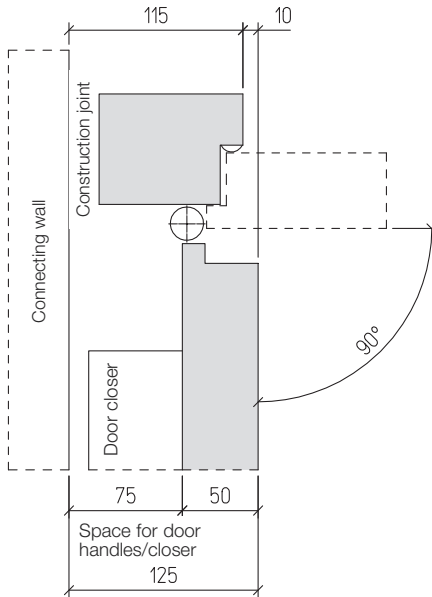

Unrebated door leaf

Thickness of door leaf 50 mm

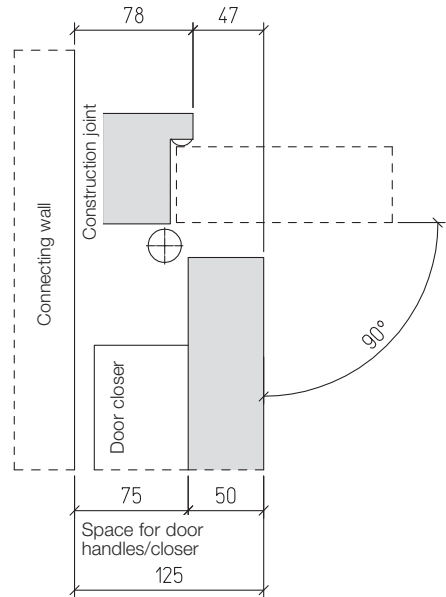

Rebated door leaf

Thickness of door leaf 70/73 mm

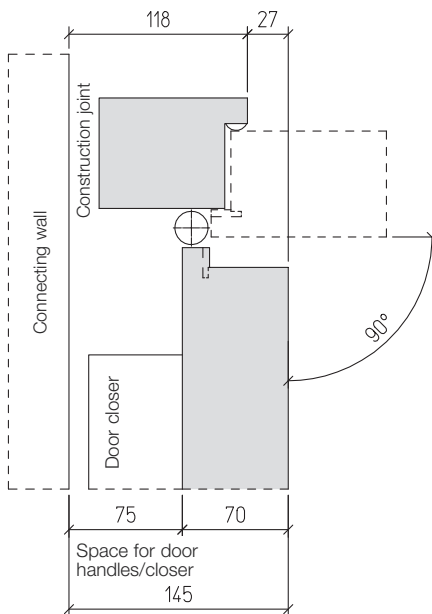

Unrebated door leaf

Thickness of door leaf 70/73 mm

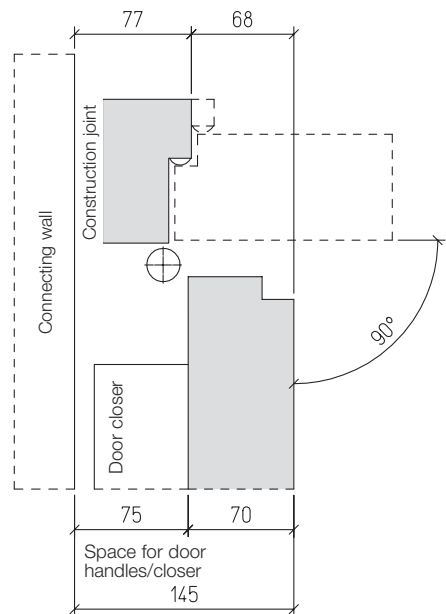

Wooden special doors

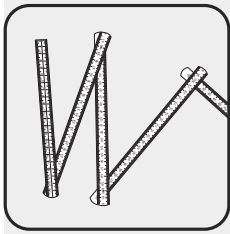

Dimensions

3.5

Aperture angle of doors

Required frame width for a 90° aperture angle

Floor-mounted door closer with pivot hinges

Valid for all frame versions

Rebated door leaf

Thickness of door leaf 50 mm

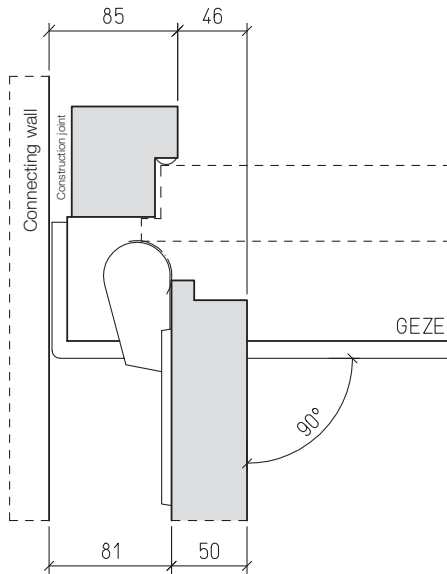

Unrebated door leaf

Thickness of door leaf 50 mm

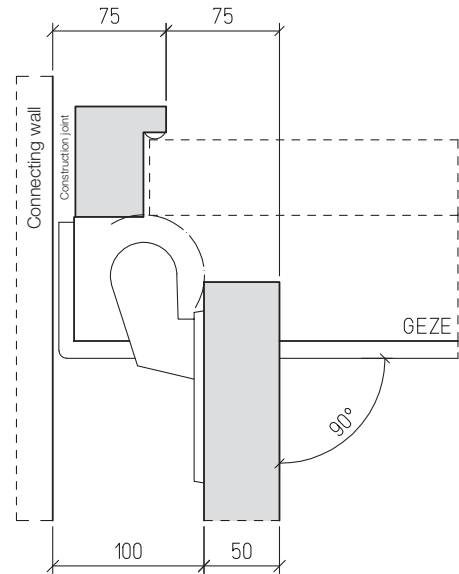

Rebated door leaf

Thickness of door leaf 70/73 mm

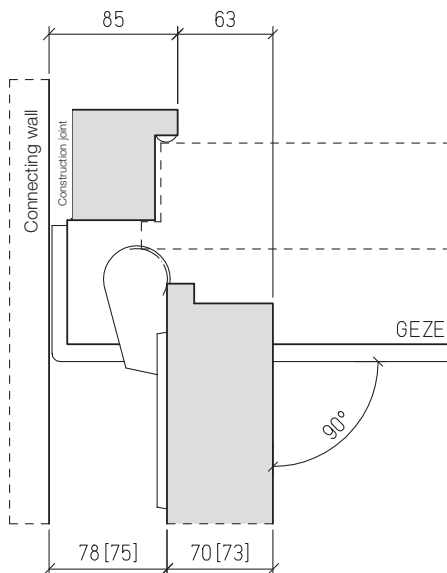

Unrebated door leaf

Thickness of door leaf 70/73 mm

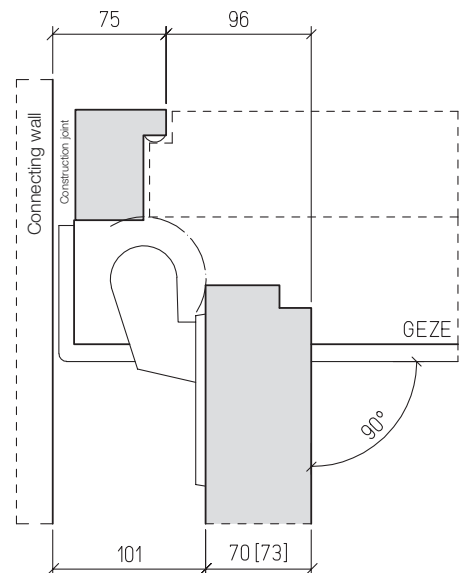

Note:

Examples shown are with GEZE door closers.
Allow 10 mm more space for DORMA door closers.

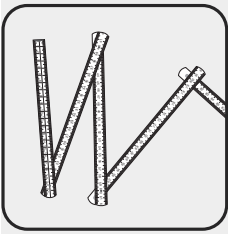

Dimensions

3.5

Aperture angle of doors

Surface-mounted and floor-mounted door closers

Surface-mounted door closer with hinges

Rebated door leaf

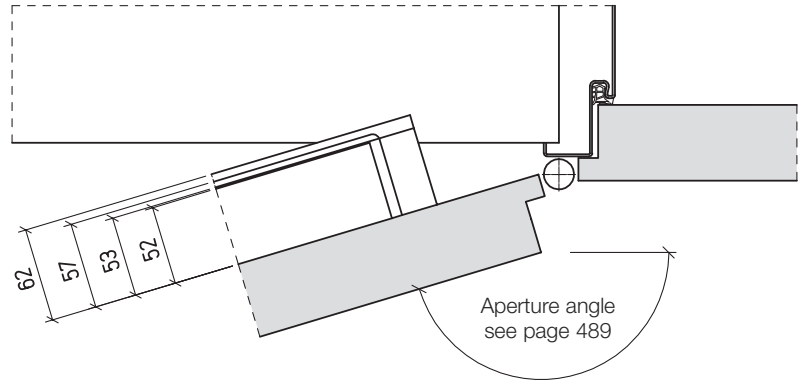

Unrebated door leaf

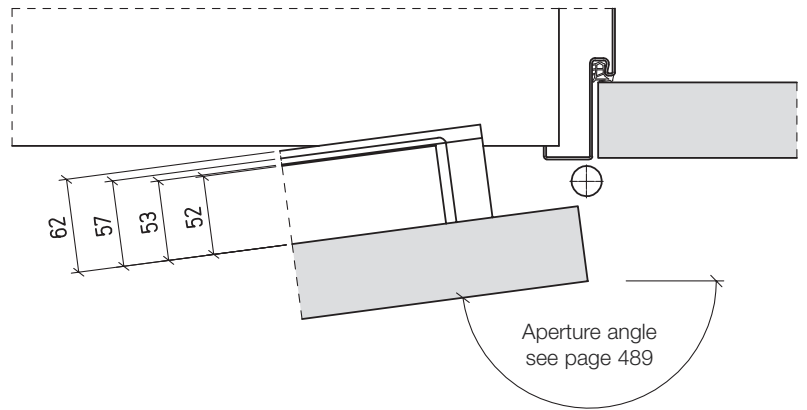

A door stop necessary!

Floor-mounted door closer with pivot hinges, 180° aperture angle

Rebated door leaf

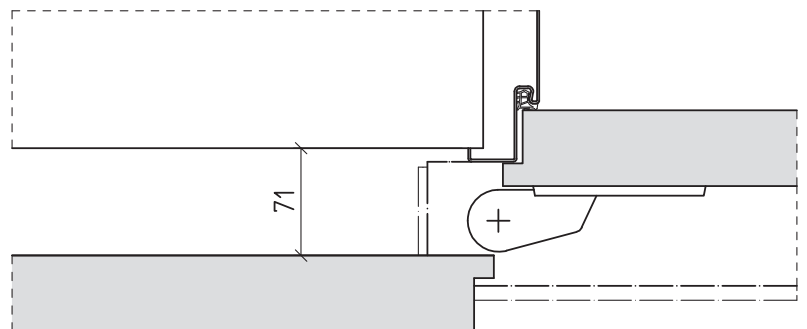

Unrebated door leaf

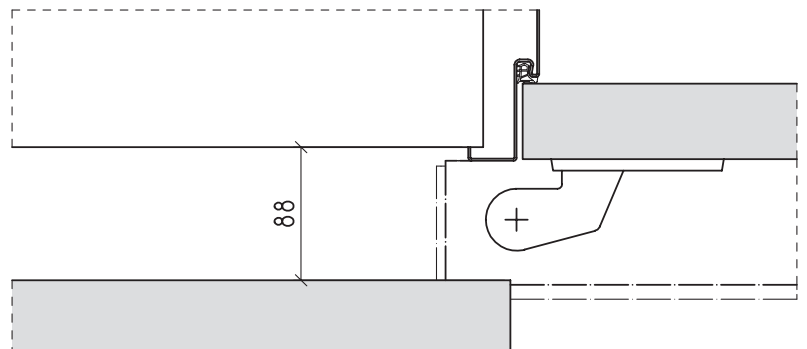

Note:

Allow enough space for handles!

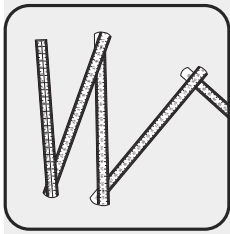

Aperture angle of doors

Steel wrap-around frames with VS-, VSX- or VX hinges

Installation type	Door closer model	Aperture angle		Figurative diagram
		Rebated (F)	Unrebated(S)	
Standard installation on pull side	GEZE TS 4000	160°	160°	
	GEZE TS 4500	160°	160°	
	GEZE TS 5000 / 5500	160°	160°	
	DORMA TS 73	160°	160°	
	DORMA TS 83	160°	160°	
	DORMA TS 93	150°	160°	
	DORMA ITS 96	110°	110°	
Transom installation on push side	GEZE TS 4000 up to jamb depth of 70 mm	180°	170°	
	GEZE TS 4000 up to jamb depth of 165 mm	115°	110°	
	DORMA TS 73 up to jamb depth of 70 mm	180°	170°	
	DORMA TS 73 up to jamb depth of 135 mm	180°	180°	
	GEZE TS 4000 With bracket for lintel installation	180°	180°	
	DORMA TS 73 With bracket for lintel installation	180°	180°	
Installation on push side	GEZE TS 5000 L GEZE TS 5500 L With bracket for lintel installation	145°	120°	
	DORMA TS 93 G With bracket for lintel installation	145°	130°	
Floor-mounted door closer with pivot hinge	GEZE BTS 550 F	180°	180°	
	DORMA BTS 80 F	180°	180°	
	GEZE BTS 550 F-G Attached slide rail	170°	180°	

Notes:

- The stated aperture angles are approximate values.
- The aperture angle can be lower, if other hinges are used.
- **Allow enough space for handles and door closer!**
- Make sure to plan enough space and recesses for surface-mounted door closer and handles.
- For steel frames with 15 mm backbend and wooden wrap-around frames the aperture angle can enlarge about 3°, up to 7°.
- For steel block frames, wooden block frames and solid wooden frames with faces flush with the wall, the aperture angle can be 5° lower.
- If the door leaf thickness is 70 respectively 73 mm (rebated configuration), the aperture angle can be 5° lower.

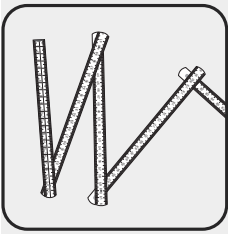

Dimensions

Minimum LD-width

3.6

Overview of 1-leaf doors

Wooden special doors

Type	Edge configuration	Door leaf hanging	Minimum LD-Width
1 N	Rebated	Hinges	561 mm
	Unrebated	Hinges	561 mm
3 N, 13 N 3-60, 3-90 3 N-NT	Rebated	Hinges	436 mm
	Rebated	BTS with pivot hinge	561 mm
	Unrebated	Hinges	561 mm
	Unrebated	BTS with pivot hinge	936 mm
	Unrebated with jamb rebate	Hinges	561 mm
	Unrebated with jamb rebate	BTS with pivot hinge	936 mm
5 N, 16 N, 50-1 5-60	Rebated, double-rebated	Hinges	561 mm
	Rebated, double-rebated	BTS with pivot hinge	936 mm
	Unrebated with jamb rebate	Hinges	561 mm
	Unrebated with jamb rebate	BTS with pivot hinge	936 mm
35 N, 17 N	Double-rebated	Hinges	561 mm
10 N	Unrebated with double jamb rebate	Hinges	¹⁾
	Unrebated with double jamb rebate	BTS with pivot hinge	¹⁾
	Double-rebated	Hinges	¹⁾
	Double-rebated	BTS with pivot hinge	¹⁾
25 N	Rebated	Hinges	561 mm
	Rebated	BTS with pivot hinge	936 mm
	Unrebated with jamb rebate	Hinges	561 mm
	Unrebated with jamb rebate	BTS with pivot hinge	936 mm
8 N, 80-1	Rebated	Hinges	561 mm
	Unrebated with jamb rebate	Hinges	561 mm
91 N	Rebated	Hinges	¹⁾
	Unrebated with jamb rebate	Hinges	¹⁾
120-1 N	Unrebated	Hinges	686 mm
25 N Slimline	Unrebated	Hinges	561 mm
91 N Slimline	Unrebated	Hinges	¹⁾

BTS = Floor-mounted door closer

¹⁾ The dimensions of the types 10 N and 91 N are, depending on the structural location, individually different.

These measure restrictions guarantee a opening of the door without any problems. Depending on the frame rebate depth, door leaf width and the hinge pivot (door leaf hanging).

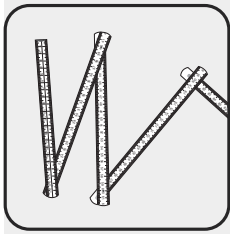

Dimensions

Minimum LD-width

3.6

Overview of 2-leaf doors

Wooden special doors

Type	Edge configuration	Door leaf hanging	Minimum LD-Width	
			Partial panic function on active leaf	Panic function on active and inactive leaf
4 N, 14 N 4-60 4 N-NT	Rebated	Hinges	1186 mm	1186 mm
	Rebated	BTS with pivot hinge	1186 mm	1436 mm
	Unrebated	Hinges	1186 mm	1186 mm
	Unrebated	BTS with pivot hinge	1186 mm	1436 mm
	Unrebated with jamb rebate	Hinges	1311 mm	1311 mm
	Unrebated with jamb rebate	BTS with pivot hinge	1311 mm	2061 mm
6 N, 26 N, 50-2 6-60	Rebated, double-rebated	Hinges	1311 mm	1311 mm
	Rebated, double-rebated	BTS with pivot hinge	1311 mm	2061 mm
	Unrebated with jamb rebate	Hinges	1311 mm	1311 mm
	Unrebated with jamb rebate	BTS with pivot hinge	1311 mm	2061 mm
20 N	Unrebated with double jamb rebate	Hinges))
	Unrebated with double jamb rebate	BTS with pivot hinge))
	Double-rebated	Hinges))
	Double-rebated	BTS with pivot hinge))
27 N	Rebated	Hinges	1311 mm	1311 mm
	Rebated	BTS with pivot hinge	1311 mm	2061 mm
	Unrebated with jamb rebate	Hinges	1311 mm	1311 mm
	Unrebated with jamb rebate	BTS with pivot hinge	1311 mm	2061 mm
24 N, 80-2	Rebated	Hinges	1311 mm	1611 mm
	Unrebated with jamb rebate	Hinges	1311 mm	1936 mm
92 N	Rebated	Hinges))
	Unrebated with jamb rebate	Hinges))
27 N Slimline	Unrebated	Hinges	1311 mm	1936 mm
92 N Slimline	Unrebated	Hinges))

BTS = Floor-mounted door closer

) The dimensions of the types 20 N and 92 N are, depending on the structural location, individually different.

These measure restrictions guarantee a opening of the door without any problems. Depending on the frame rebate depth, door leaf width and the hinge pivot (door leaf hanging).

2-leaf doors with panic function on active and inactive leaf, have generally to be equipped with a carrier bar.

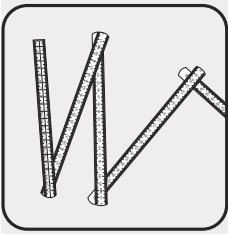

Dimensions

3.7

Opening direction

1-leaf and 2-leaf doors

The labeling of a door leaf as DIN right or DIN left results from the pull side. For 2-leaf doors DIN direction is determined by the active leaf.

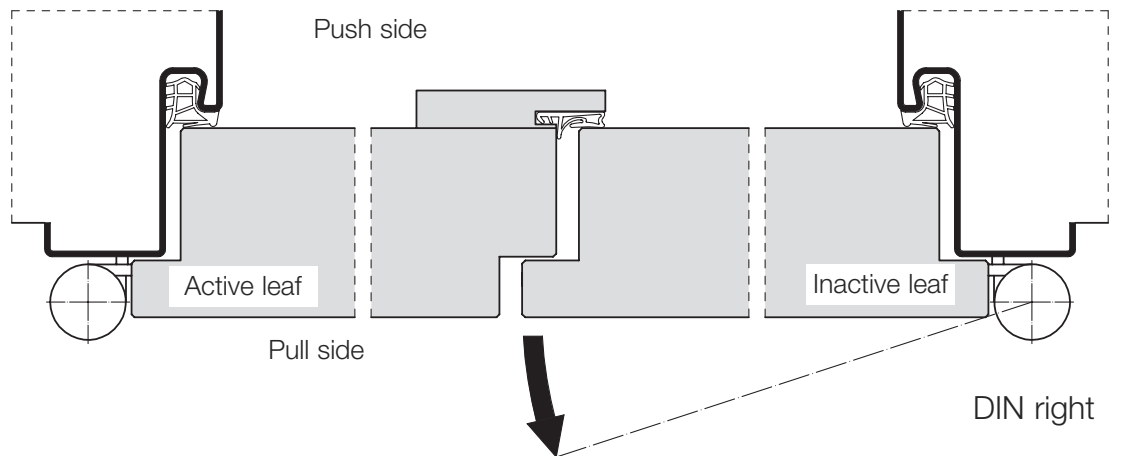
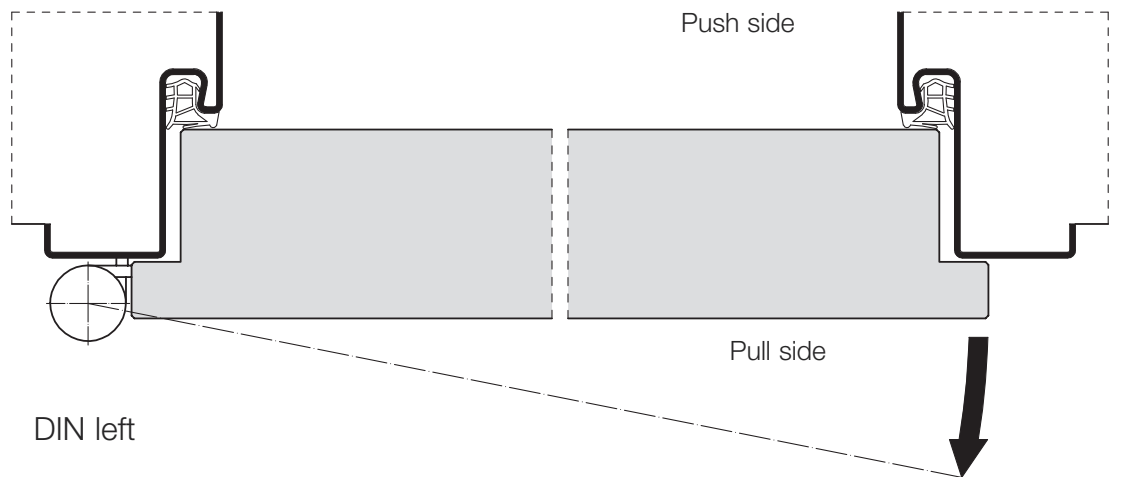

Wooden special doors

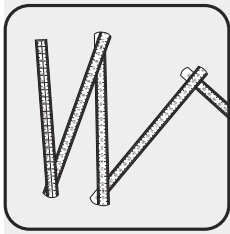

Dimensions

3.8

Dimensional measurement form

Door sets

Wooden special doors

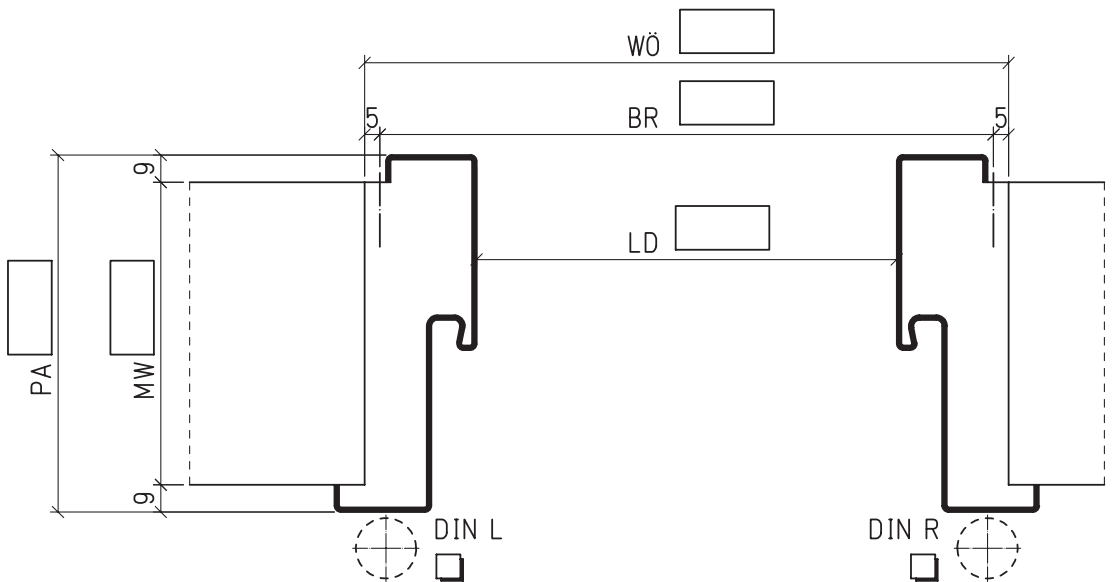
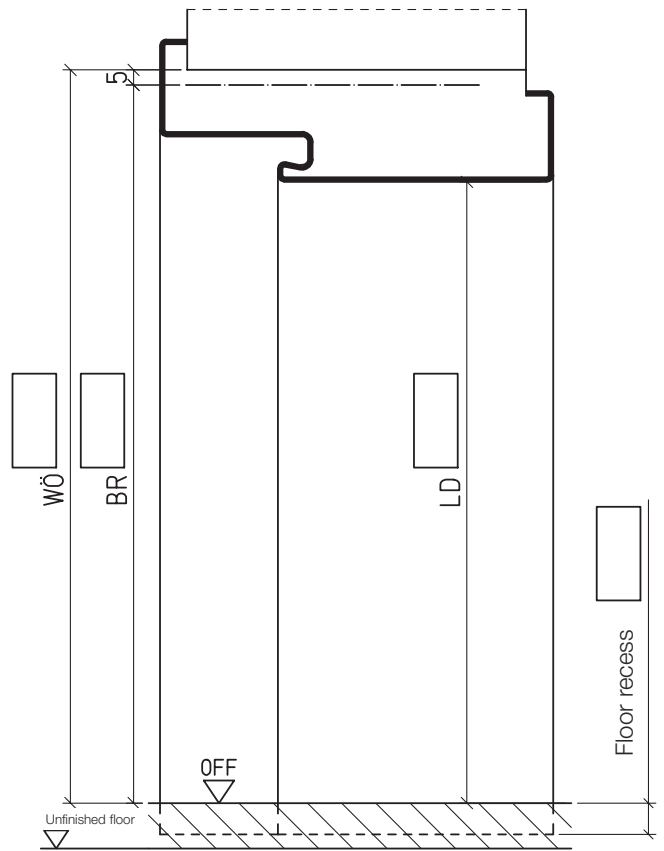
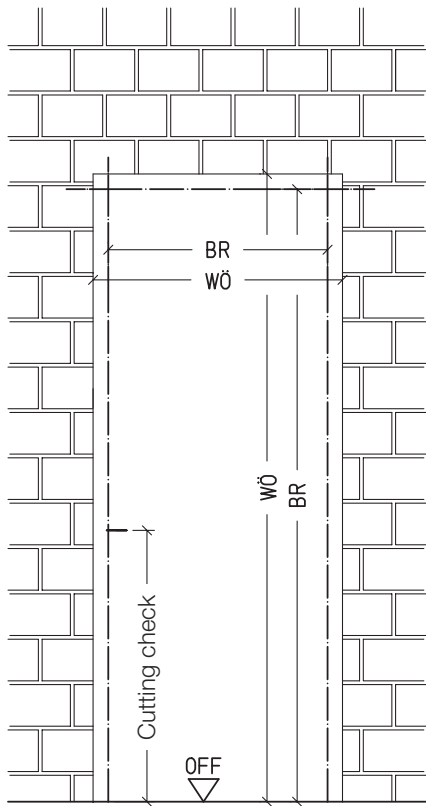

Pos.	Door No.	Door leaf edge		Height of the handles	Door leaf height for door sets with top panel
		Rebated	Unrebated		

WÖ = Wall opening
PA = Overall frame depth

BR = Basic dimension
LD = Clear passage

MW = Throat opening

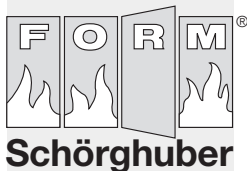

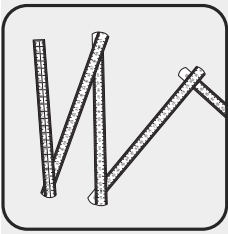

Dimensions

3.8

Dimensional measurement form

Door leaf for existing frames

Wooden special doors

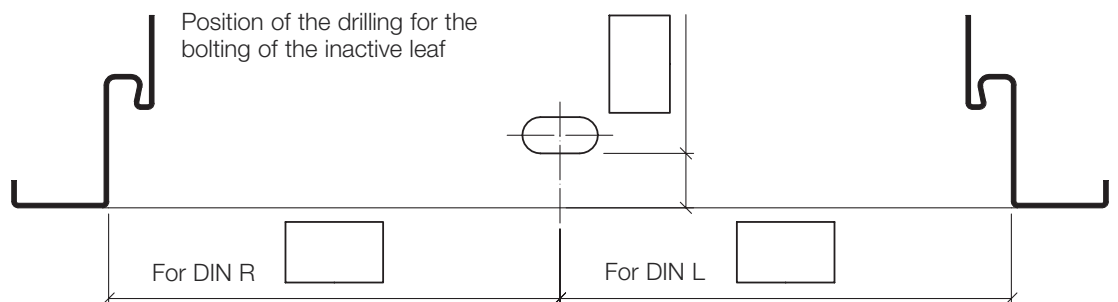
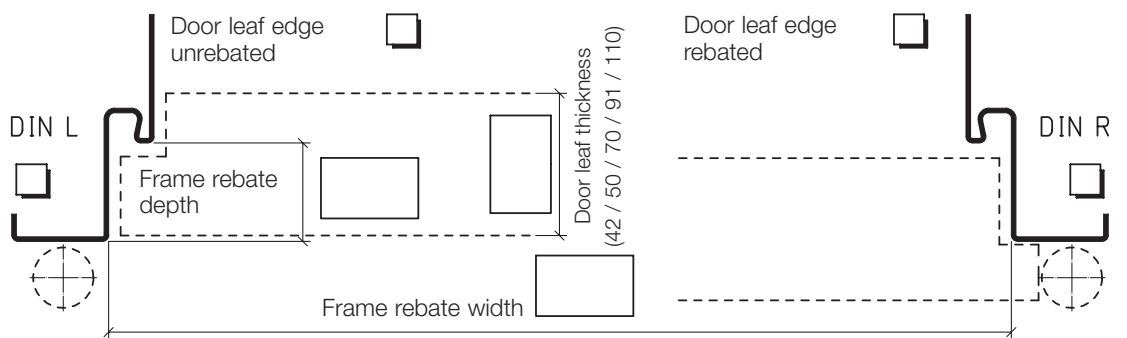
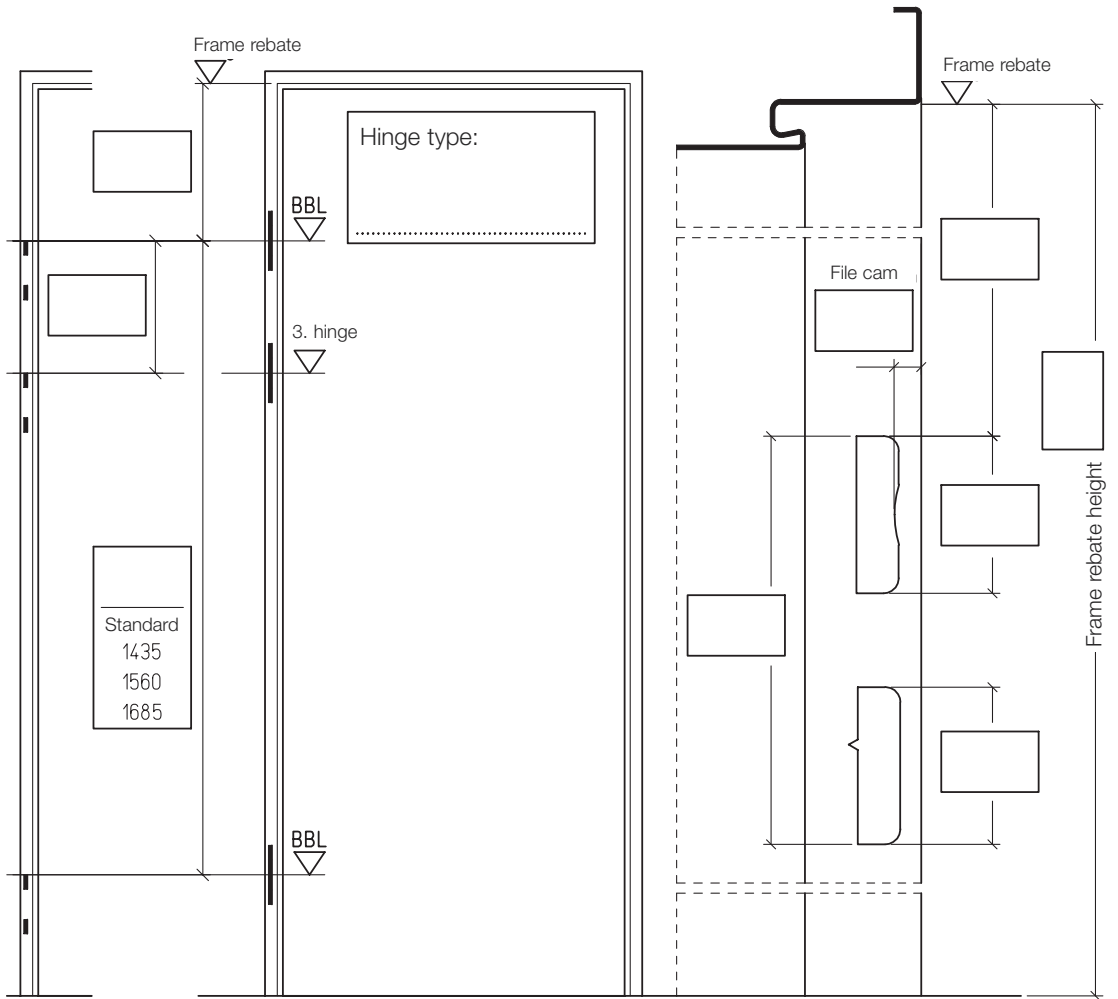

See steel frames respectively wooden frames for details of the reconstruction frame.
 ➔ Chapter "Frames"