

Door closers

Content

	Page
14.1 General information	1004 - 1007
14.2 Overhead door closers with projecting arm	1008 - 1011
14.3 Overhead door closers with slide rail	1012 - 1018
14.4 Concealed door closers	1019 - 1025
14.5 Floor-mounted door closer	1026 - 1029
14.6 Automatic door operators	1030 - 1042
14.7 Overhead door closers for smoke and heat venting systems	1043 - 1046
14.8 Hold-open devices	1047 - 1050

Door closers

General information

Configurations

Fields of application

The main purpose of door closers is to automatically close doors after they were opened manually. The hereby necessary energy is generated during the opening procedure and stored in form of mechanical energy (springs). The closing procedure is hydraulically damped, whereas the damping level, the closing pressure and additional functions are adjustable, depending on the model of the door closer.

Reasons to close a door automatically can be:

- Fire and smoke protection
- Security aspects
- Protection of privacy
- Energy saving
- Avoiding of bothersome draught
- Lockout of noise and other environmental stress

DIN EN-standards regulate testings of door closer parts as well as their use. Hereby door closers are divided in:

- Overhead door closers with projecting arm
- Overhead door closers with slide rail
- Floor-mounted door closers
- Automatic door operators
- Door closers with hold-open device and with or without free-swing function, on request with integrated smoke detector.

Spring hinges

Doors with secondary function such as T 30 doors or flaps can be equipped with spring hinges in combination with a 3-parted hinge. These fittings regulated in DIN 18262 are available in various surface configurations. ➔ Chapter hinges

Design concept

During the design process of the door the choice of the door closer type as well as its installation option should be considered. Door closers as well as their cover plates and protective caps can be delivered, matching the surface configurations of the other door fittings. Available surface configurations for door closers are silver-coloured, stainless steel, brass, RAL-coloured etc.

The modern architecture prefers solutions, especially for Fire- and Smoke-Protection-Doors in high-quality building projects, which keep technical details in the background. Suitable door closers are for example floor-mounted door closers or concealed door closer systems (integrated in door leaf and door frame), which do not disturb the visual appearance of the door set.

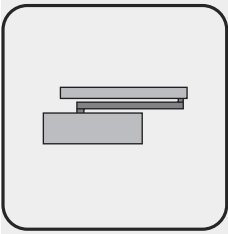

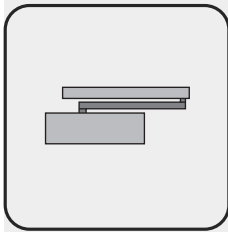

Door closers

14.1

General information

Standards

In the context of the work of the CEN (European committee for standardisation) three European standards were issued:

DIN EN 1154 Locks and fittings,
door closers with controlled closing procedure,
requirements and testing procedures

This DIN covers among other things

- Overhead door closers with projecting arm
- Overhead door closers with slide rail
- Integrated, concealed-mounted door closers
- Floor-mounted door closer

DIN EN 1155 Locks and fittings,
electrically operated hold-open devices for door closers,
requirements and testing procedures

DIN EN 1158 Locks and fittings,
door coordination,
requirements and testing procedures

The DIN 18263, part 4 (door closers with automatic opening operation) is not affected by the three EN-standards mentioned above, but it was revised and published, simultaneously with the issuing of the DIN EN 1154, in an adapted design.

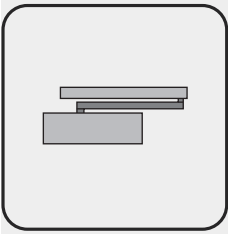

Door closers

14.1

General information

Functions

Door closers can be equipped with various functions, which can be combined to a certain extend.

Closing pressure

With the help of an allen key the closing pressure of the most door closers can be adjusted infinitely variable. The required closing pressure is orientated according to the door leaf width and the door leaf weight. According to EN 1154 the closing pressure for Fire- and Smoke-Protection-Doors has to be adjustable to at least door closer-size 3.

Closing speed

Allows the infinitely variable adjustment of the closing time.

Shock absorbing action

In order to assure a secure locking of the latch the damping of the door closer has to be adjustable, allowing the shock absorbing action to be neutralised if the door leaf reaches an aperture angle of approximately 7°.

Opening damping action

If adjusted accordingly, the momentum of an impetuously pushed open door can be slowed from a defined aperture angle on. The chance of the door closer the handles and the wall being damaged is reduced. In certain application areas, for example a door opening to the outside, the opening damping action can not replace the door stop.

Closing time delay

If adjusted accordingly, the time for the door closing procedure can be extended within an aperture angle of 70° and 120°. This allows enough time to be able to walk through the door.

Door coordination

According to DIN EN 1158 door coordination mechanisms are installed where a correct door coordination of 2-leaf door sets is required, for example for door sets with rebated meeting stiles. The door coordination guarantees that the active leaf is held open until the inactive leaf is completely shut.

Modern door coordination mechanisms are connected with the door closer and form a inter-coordinated assembly. Among these integrated systems also door closers with door coordination functioning with electromagnetic hold-open devices are available. Herby the active leaf is held open mechanically by the door coordination, while the inactive leaf is held open electromagnetically. If the power supply is cut off - for example in the event of an alarm - it is assured that the inactive leaf and the active leaf close in the right order.

Free-swing function

Self-closing doors can be, due to the to overcome closing pressure, a handicap for older, weak or frail people. But there are mechanisms which serve the needs of the door users and the fire protection requirements, in this case the self-closing function. These so called free-swing function door closers allow the user to operate the door without the closing or opening pressure of a spring. If the power supply of the door closer is cut off the self-closing function is reactivated. The free-swing function is available for door closers with projecting arm, door closers with slide rail (DORMA TS 99 FL respectively FLR and GEZE TS 5000 EFS respectively RFS) and certain floor-mounted door closers (DORMA BTS 80 FLB).

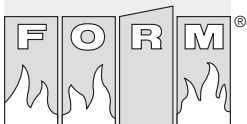
**Schörghuber**

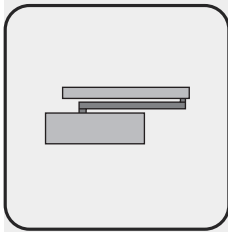

Door closers

14.1

General information

Functions

Electrohydraulic hold-open device

The hold-open device of door closers with projecting arm (DORMA or GEZE) is electro-hydraulic operated, within a range of approximately 75° and up to 180°. Hereby a springback, the additional range the door has to be opened in order to lock the door in place, of about 3° has to be taken into account. If the door is locked in place once more, additional tolerances of up to - 3° can occur. To some extent hydraulically locked doors can change their position over a longer period of time (creep behaviour).

DORMA floor-mounted door closer are electrohydraulically locked, covering a range of approximately 75° up to 180°. The springback of the hold-open device is about 3°. If the door is locked in place once more, additional tolerances of up to - 3° can occur. A creeping behaviour of the door over a longer period of time is eliminated.

Electromechanical hold-open device

Door closers with slide rail are electromechanically locked in place in the area of approximately 80 °– 130° (GEZE) respectively 80° – 120° (DORMA). Concealed door closers (DORMA ITS 96 EMF) can be locked in place in an area of about 80° – 110°. If equipped with an electromechanical hold-open device, only a very minor springback of 0,5° has to be taken into account. A creeping behaviour of the door over a longer period of time is eliminated.

GEZE floor-mounted door closers are as well electromechanically locked in place in an area of approximately 80° – 180°. The springback of the hold-open device is about 2° to 3°. If the door is locked in place once more, additional tolerances of up to - 2° can occur. A creeping behaviour of the door over a longer period of time is eliminated.

Hold-open function with electromagnet

Long-term reliable, precise door setting, e.g. in hallway wall recesses can only be realised with electromagnets.

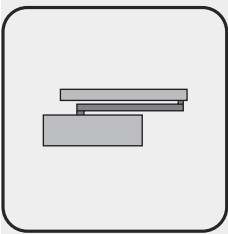

Door closers

Overhead door closers

with projecting arm

Technical terms

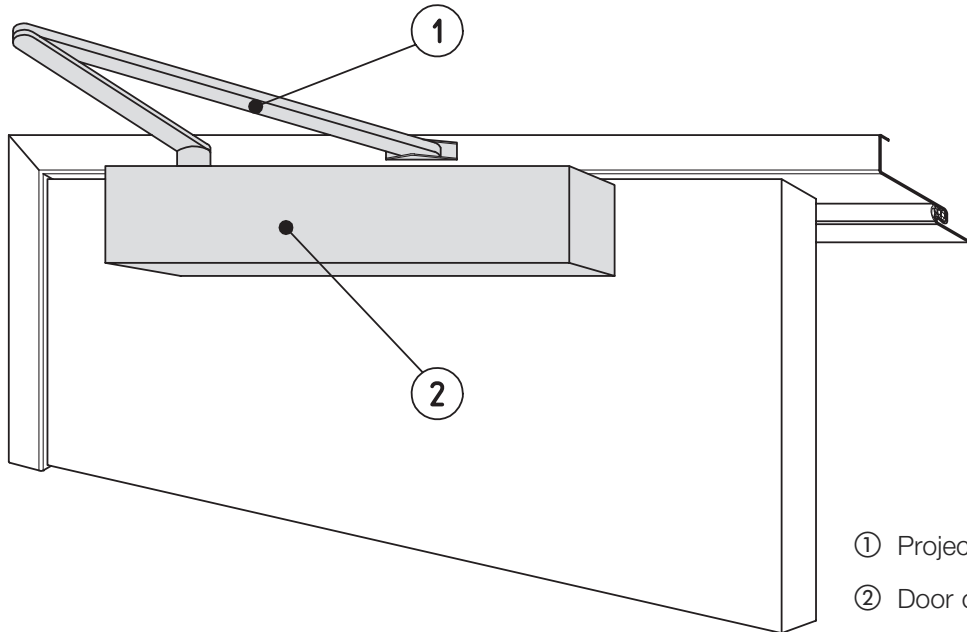

Equipment

1-leaf Schörghuber Fire- and Smoke-Protection-Doors are by default equipped with a door closer with projecting arm. 2-leaf doors are by default equipped with a door closer with continuous slide rail and integrated door coordination. On request also 2-leaf doors can be equipped with door closers with projecting arm. The door coordination is then activated by a triggering roll in the frame rebate.

Advantage

Besides the advantage regarding the price this reliable door closer offers the possibility to open the door in a 75° up to 180° angle, as well as its hold-open device available in this range.

Door closers with projecting arm can furthermore be equipped with so called free-swing arms.

The standard equipment of the door closer with projecting arm includes the adjustability of the closing pressure, the closing speed, the shock absorbing action and the opening damping action. Additional functions such as the closing time delay or the free-swing function are available on request.

The surface configuration is by default silver-coloured, on request white, RAL-coated or dark bronze.

If door closers with projecting arm are mounted in transom installation on push side, they allow a larger aperture angle than other door closers.

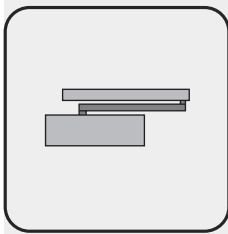

Door closers

14.2

Overhead door closers

with projecting arm

Function overview

Type of the door closer	Adjust. closing pressure nach DIN EN 1154	Adjustable closing speed	Shock absorbing action	Adjustable opening damping action	Adjustable closing time delay	Electrohydraulic hold-open device	Electromechanical hold-open device	Free-swing function with integrated hold-open device	Integrated smoke switch	Integrated door coordination (with triggering roll)
1-leaf door sets										
TS FORM	3 - 4		x							
DORMA TS 73	2 - 6	x	x							
DORMA TS 83	2 - 6	x	x	x						
DORMA TS 83 SV	2 - 6	x	x	x	x					
DORMA TS 73 EMF	2 - 6	x	x			75-180°				
DORMA TS 73 FLT	2 - 6	x	x					x		
DORMA TS 73 EMR	2 - 6	x	x			75-180°			x ¹⁾	
DORMA TS 73 FLR	2 - 6	x	x					x	x ¹⁾	
GEZE TS 4000	1 - 6	x	x	x						
GEZE TS 4000	5 - 7	x	x	x						
GEZE TS 4000 S	1 - 6	x	x	x	x					
GEZE TS 4000 E	1 - 6	x	x			80-180°		x		
GEZE TS 4000 EFS	1 - 6	x	x						x ¹⁾	
GEZE TS 4000 R	1 - 6	x	x			80-180°		x	x ¹⁾	
GEZE TS 4000 RFS	1 - 6	x	x							
2-leaf door sets										
GEZE TS 4000 IS	1 - 6	x	x	x						x
GEZE TS 4000 E-IS-G	1 - 6	x	x			80-180° (GF)				x
GEZE TS 4000 E-IS	1 - 6	x	x			80-180°				x
GEZE TS 4000 R-IS-G	1 - 6	x	x			80-180° (GF)			x ¹⁾	x
GEZE TS 4000 R-IS	1 - 6	x	x			80-180°			x ¹⁾	x

GF = hold-open device of the active leaf

¹⁾ Door closer in transom installation on push side

The GEZE TS 4000 without protective cap is similar to GEZE TS 4500 with protective cap.

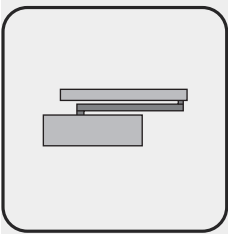

Door closers

Overhead door closers

Installation options for door closers with projecting arm

Standard installation

Pull side, rebated door leaf edge

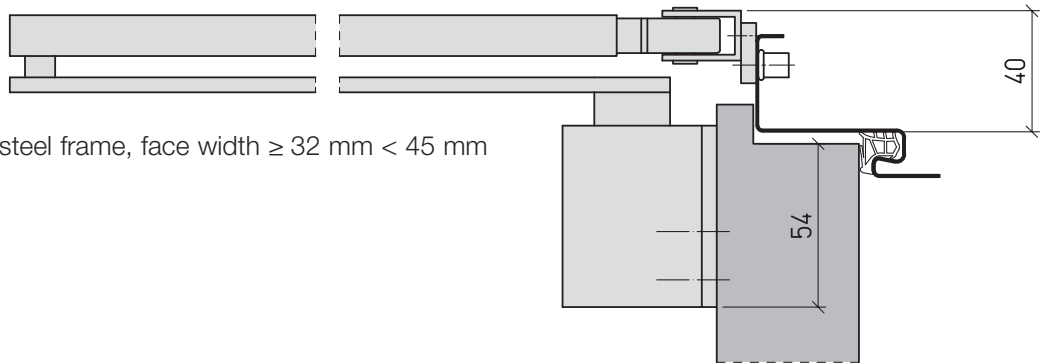

steel frame, face width ≥ 32 mm < 45 mm

Standard installation

Pull side, rebated door leaf edge

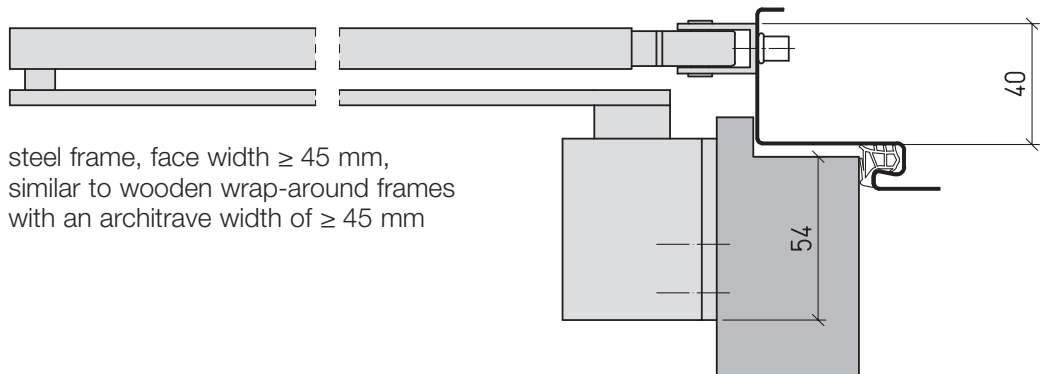

steel frame, face width ≥ 45 mm,
similar to wooden wrap-around frames
with an architrave width of ≥ 45 mm

Standard installation

Pull side, unrebrated door leaf edge

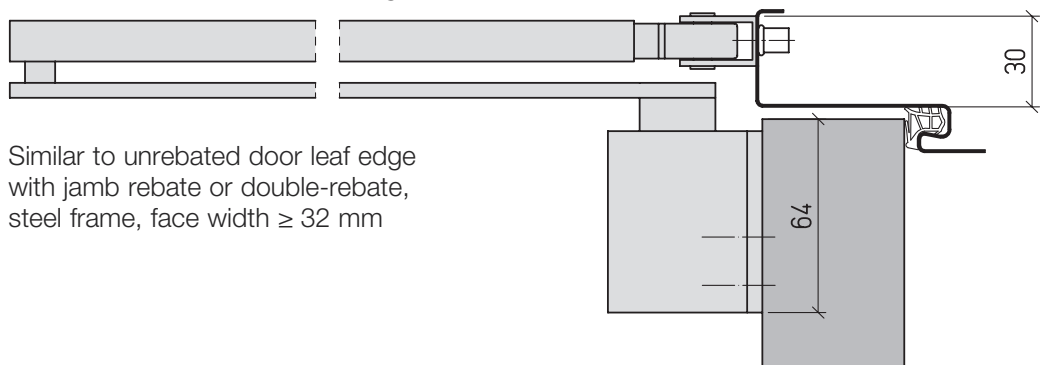

Similar to unrebrated door leaf edge
with jamb rebate or double-rebate,
steel frame, face width ≥ 32 mm

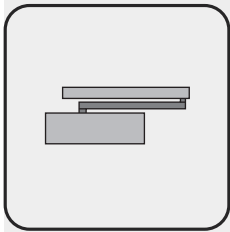

Door closers

14.2

Overhead door closers

Installation options for door closers with projecting arm

Transom installation

Push side

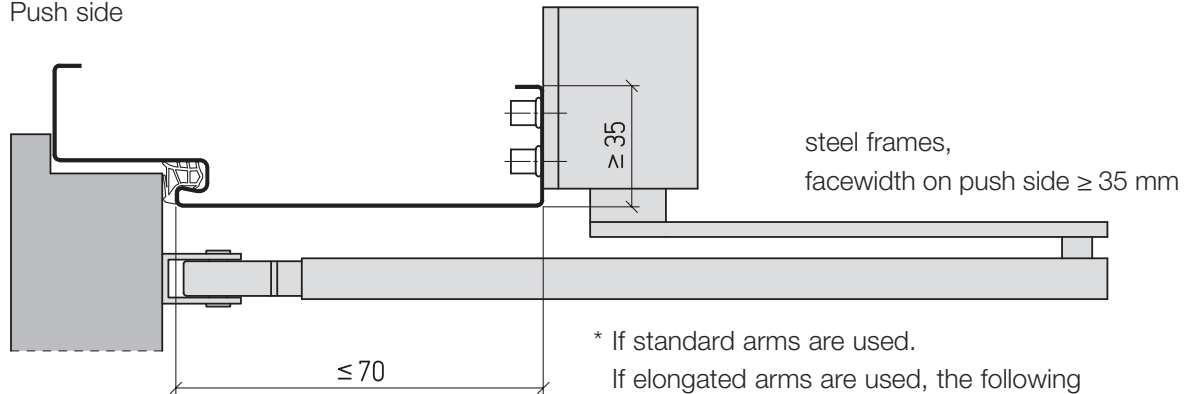

* If standard arms are used.
If elongated arms are used, the following applies:

DORMA > 70 ≤ 135 mm

GEZE > 70 ≤ 165 mm

Transom installation with bracket for transom installation

Push side, standard installation

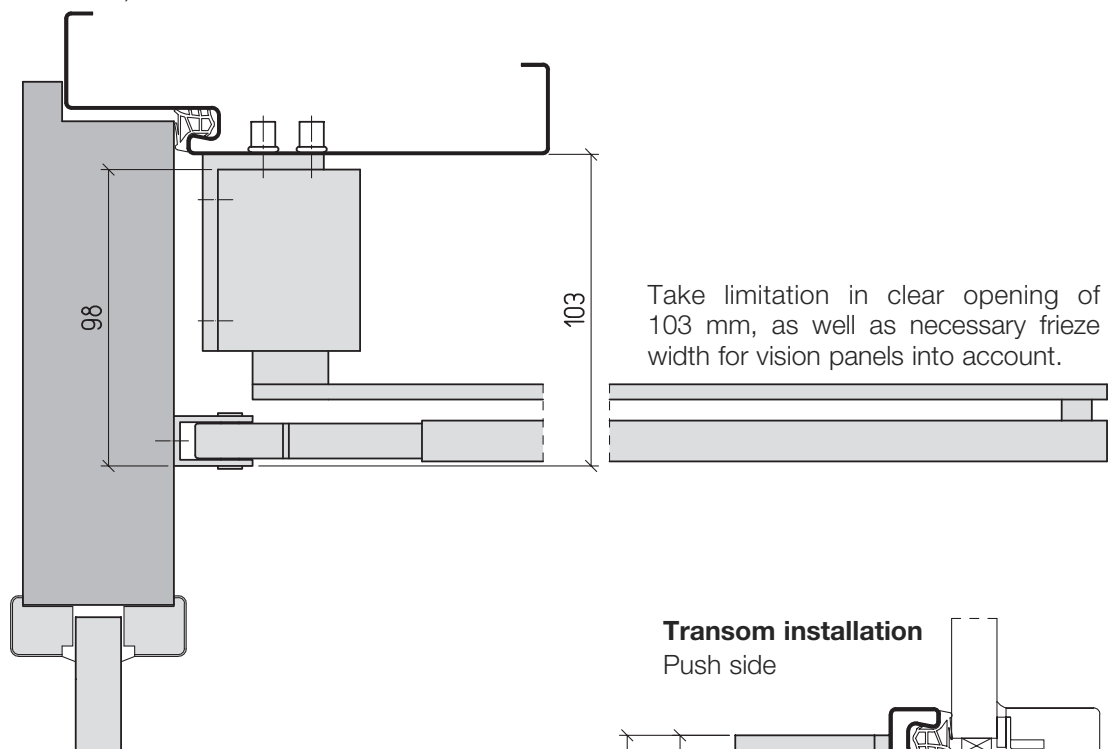

Transom installation

Push side

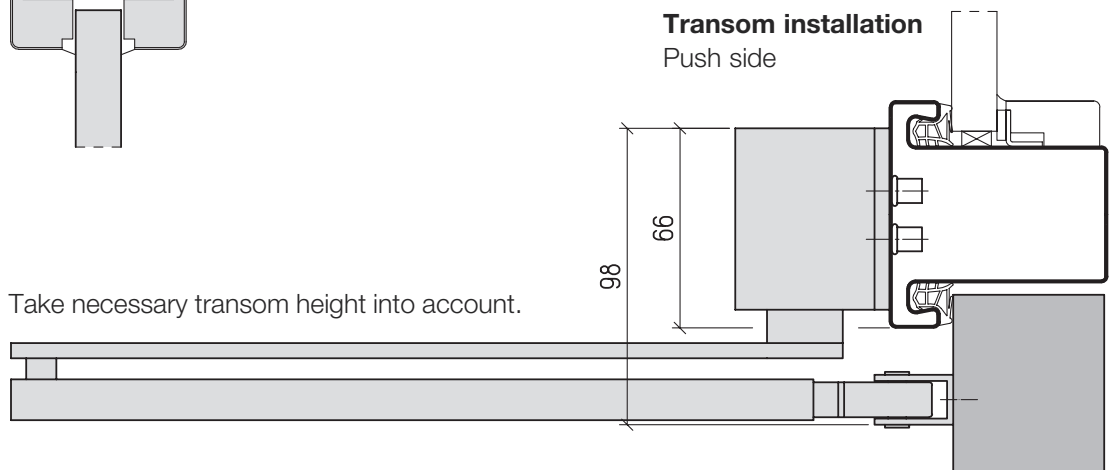

Wooden special doors

Door closers

Overhead door closers

Slide rail

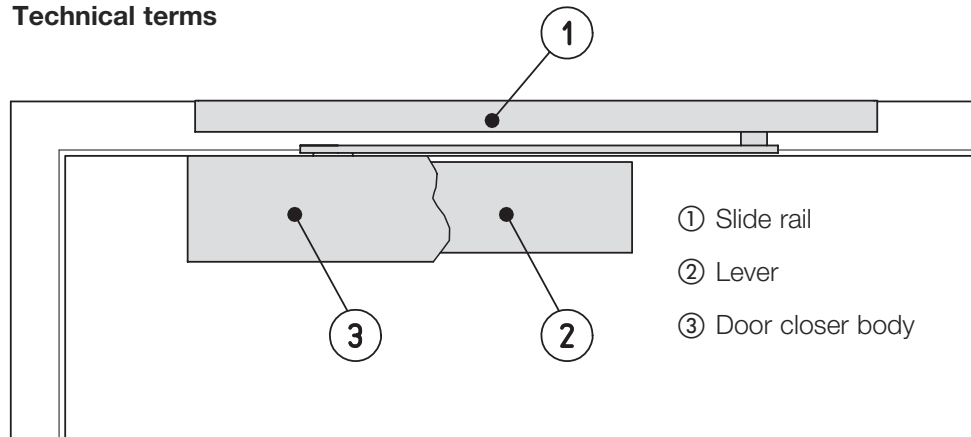
Technical terms**Equipment**

1-leaf Schörghuber Fire- and Smoke-Protection-Doors are on request equipped with a door closer with slide rail. 2-leaf Fire- and Smoke-Protection-Doors are by default equipped with a door closer with continuous slide rail and integrated door coordination.

Advantage

The essential advantage of the door closer with slide rail is the improved visual appearance of this flat on the door frame and door leaf mounted door closer. Due to the design of the door closer no parts project into the room, therefore the risk of injury and damage is, to a large extent, avoided.

Due to the technical configuration a clearly lower effort, compared to a door closer with projecting arm, is necessary to open the door.

The standard equipment of the door closer with slide rail includes the adjustability of the closing pressure, the closing speed, the shock absorbing action, the opening damping action and partly the closing time delay.

The door closers with slide rail can be equipped with an integrated electromechanical hold-open device. With this an infinitely variable locking of the door in the area of approximately 80 – 120° (DORMA TS 93) and approximately 80 – 130° (GEZE TS 5000) is possible. Other than the DORMA TS 93, the GEZE TS 5000 allows the operator to open the door beyond the locking point. Aperture angle, see chapter 3.5.

An additional free-swing function is offered by the DORMA TS 99 FL, FLR respectively FLR/K and the GEZE TS 5000 EFS respectively RFS.

The standard configuration is equipped with a silver-coloured protective cap. The protective caps can on request be delivered RAL-coated, dark bronze or also brass polished or also in stainless steel configuration, matt or polished.

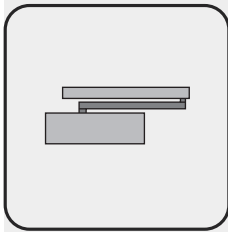

Door closers

14.3

Overhead door closers

Slide rail

Function overview

Type of the door closer	Adjust. closing pressure acc. to DIN EN 1154	Adjustable closing speed	Shock absorbing action	Adjustable opening damping action	Adjustable closing time delay	Electromechanical hold-open device approx.	Integrated smoke switch	Door coordination integrated in the continuous slide rail	Free-swing function
1-leaf door sets									
TS FORM G	2 - 4	x	x						
GEZE TS 3500 V ¹⁾	2 - 4	x	x						
GEZE TS 5500 ²⁾	2 - 6	x	x	x					
GEZE TS 5500 S ²⁾	2 - 6	x	x		x				
GEZE TS 5500 E ²⁾	2 - 6	x	x	x		80-130°			
GEZE TS 5500 R ²⁾	2 - 6	x	x	x		80-130°	x		
GEZE TS 5500 EFS	2 - 5		x						x
GEZE TS 5500 RFS	2 - 5		x				x		x
DORMA TS 93	$\frac{2}{5} - \frac{5}{7}$	x	x	x	x				
DORMA TS 93 EMF ³⁾	$\frac{2}{5} - \frac{5}{7}$	x	x	x	x	80-120°			
DORMA TS 93 EMR	$\frac{2}{5} - \frac{5}{7}$	x	x	x	x	80-120°	x		
DORMA TS 99 FL ¹⁾	4	x							x
DORMA TS 99 FLR ¹⁾	4	x					x		x
DORMA TS 99 FLR/K	4	x					x		x

Wooden special doors

¹⁾ Door leaf width ≤ 1100 mm, door leaf weight max. 80 kg

²⁾ Door leaf width ≤ 1400 mm

³⁾ EMF = TAB max. 1250 mm

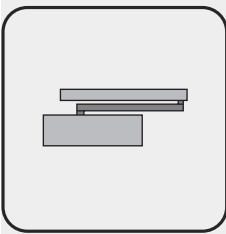

Door closers

Overhead door closers

Slide rail

Function overview

Type of the door closer	Adjust. closing pressure acc. to DIN EN 1154	Adjustable closing speed	Shock absorbing action	Adjustable opening damping action	Adjustable closing time delay	Electromechanical hold-open device approx.	Integrated smoke switch	Door coordination integrated in the continuous slide rail	Free-swing function
2-leaf door sets									
GEZE TS 5500 IS ²⁾	2 - 6	x	x	x				x	
GEZE TS 5500 E-IS/G ²⁾	2 - 6	x	x	x		80-130° (GF)		x	
GEZE TS 5500 E-IS ²⁾	2 - 6	x	x	x		80-130°		x	
GEZE TS 5500 R-IS/G ²⁾	2 - 6	x	x	x		80-130° (GF)	x	x	
GEZE TS 5500 R-IS ²⁾	2 - 6	x	x	x		80-130°	x	x	
DORMA TS 93 GSR	2 - 5 5 - 7	x	x	x	x			x	
DORMA TS 93 GSR-EMF 1G	2 - 5 5 - 7	x	x	x	x	80-120° (GF)		x	
DORMA TS 93 GSR-EMF 1	2 - 5 5 - 7	x	x	x	x	80-120° (SF)		x	
DORMA TS 93 GSR-EMF 2	2 - 5 5 - 7	x	x	x	x	80-120°		x	
DORMA TS 93 GSR-EMR 1G	2 - 5 5 - 7	x	x	x	x	80-120° (GF)	x	x	
DORMA TS 93 GSR-EMR 1	2 - 5 5 - 7	x	x	x	x	80-120° (SF)	x	x	
DORMA TS 93 GSR-EMR 2	2 - 5 5 - 7	x	x	x	x	80-120°	x	x	
DORMA GF: TS 99 FL SF: TS 93 GSR	4 2 - 5	x						x	x (GF)
DORMA GF: TS 99 FL SF: TS 93 GSR-EMF 1	4 2 - 5	x				80-120° (SF)		x	x (GF)
DORMA GF: TS 99 FL SF: TS 93 GSR-EMR 1	4 2 - 5	x				80-120° (SF)	x	x	x (GF)

Wooden special doors

GF = hold-open device of the active leaf

SF = hold-open device inactive leaf, hold-open device active leaf over door coordination

¹⁾ Door leaf width ≤ 1100 mm, door leaf weight max. 80 kg

²⁾ Door leaf width ≤ 1400 mm

³⁾ EMF = TAB max. 1250 mm



Schörhuber

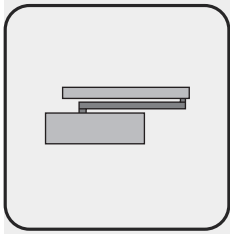

Door closers

14.3

Overhead door closers

Installation options for door closers with slide rail

Wooden special doors

Standard installation

Pull side

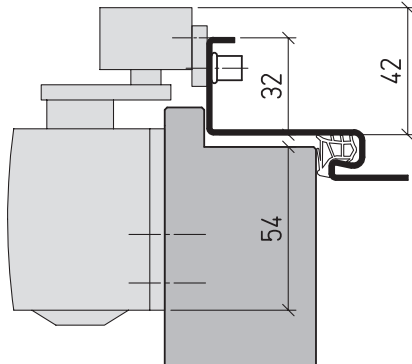

Face \geq 40 mm without intermediate board

Standard installation

Pull side

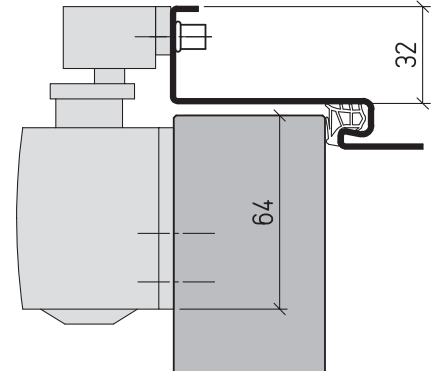

Standard installation

Push side

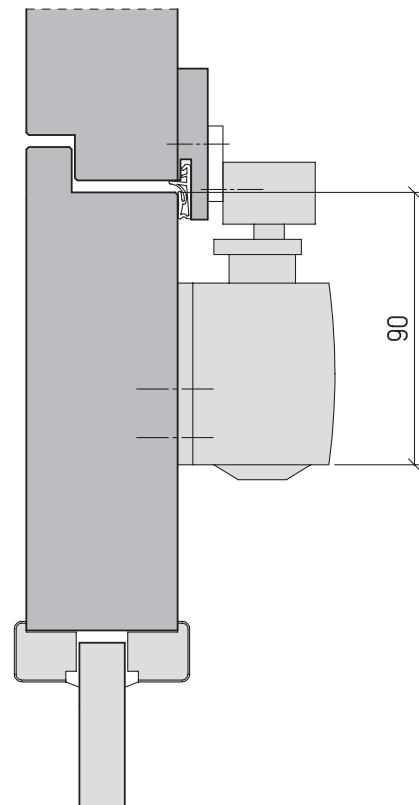

In combination with solid wooden frame, similar to unrebated door leaf edge with jamb rebate or counter rebated to the top panel respectively the transom.

Not for 2-leaf doors with door coordination.

Take the necessary frieze width for vision panels into account.

Standard installation

Push side, counter rebated door leaf edge

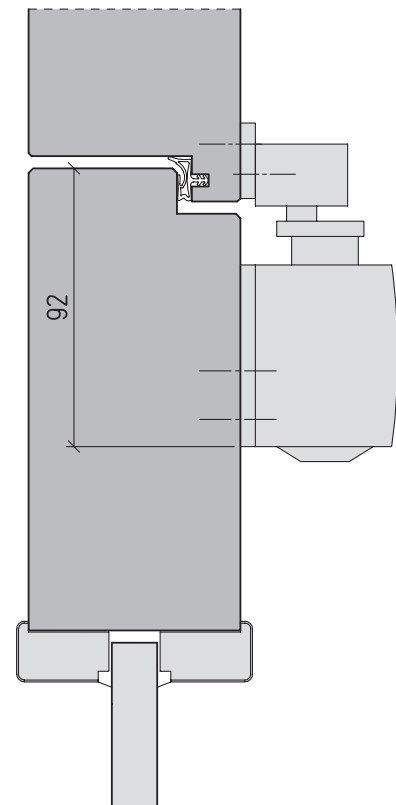

In combination with top panel

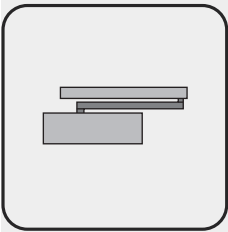

Door closers

14.3

Overhead door closers

Installation options for door closers with slide rail

Wooden special doors

Transom installation

Pull side, rebated door leaf edge

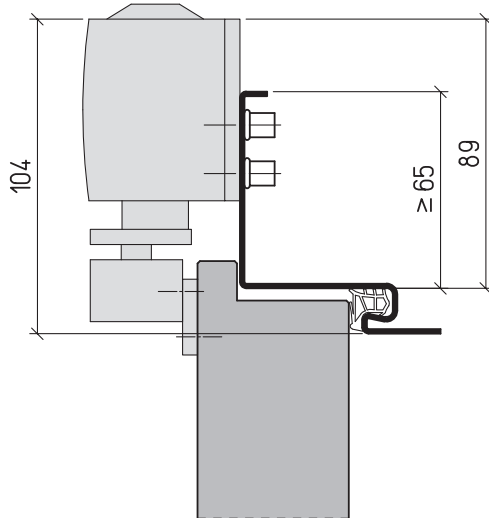

For 1-leaf doors only

Transom installation

Pull side, unrebated door leaf edge

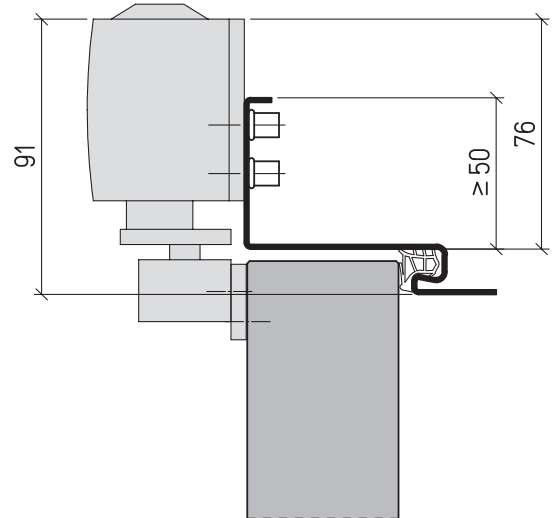

Similar to unrebated door leaf edge with jamb rebate or double-rebate (solid wooden frame), for 1-leaf doors only

Transom installation

Push side, unrebated door leaf edge

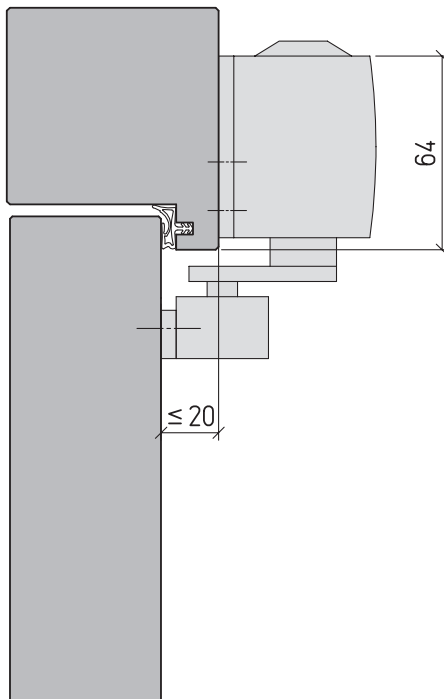

Similar to unrebated door leaf edge with jamb rebate or double-rebate.

Take the necessary solid wooden frame width into account.

Standard installation with bracket for transom installation

Push side, standard installation

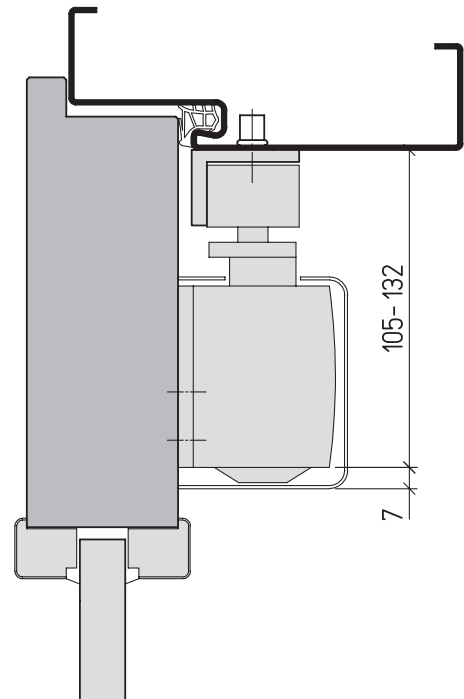

Rebated door leaf edge, similar to unrebated door leaf edge, unrebated with jamb rebate or double-rebate.

Take the necessary frieze width for vision panels into account.

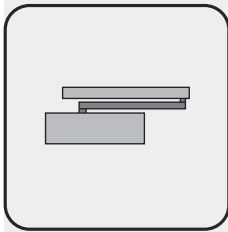

Door closers

14.3

Overhead door closers

Door closer with slide rail, min. dimensions for 1-leaf doors

Standard installation

Pull side

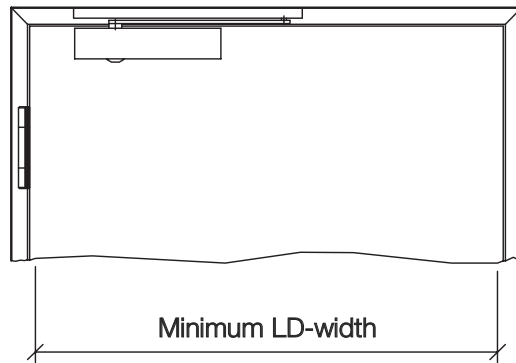

Type of the door closer	LD-width
TS FORM G	≥ 525 mm ≤ 1080 mm
GEZE TS 3500 V	≥ 525 mm ≤ 1080 mm
GEZE TS 5500	≥ 525 mm
GEZE TS 5500 E	≥ 525 mm
GEZE TS 5500 R	≥ 735 mm
GEZE TS 5500 EFS	≥ 525 mm
GEZE TS 5500 RFS	≥ 735 mm
DORMA TS 93	≥ 525 mm
DORMA TS 93 EMF	≥ 570 mm
DORMA TS 93 EMR	≥ 760 mm
DORMA TS 99 FL	≥ 525 mm ≤ 1078 mm
DORMA TS 99 FLR/K	≥ 525 mm ≤ 1078 mm

Standard installation with bracket for transom installation

Standard installation, push side

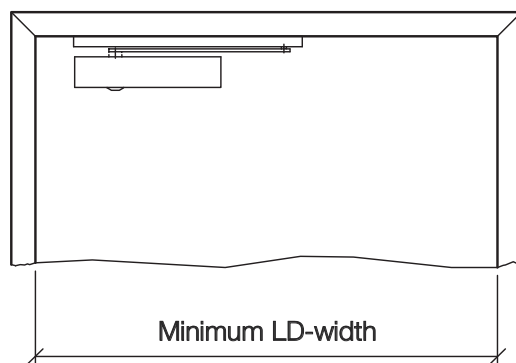

Type of the door closer	LD-width
GEZE TS 5500 L	≥ 560 mm
DORMA TS 93 G	≥ 565 mm
DORMA TS 93 G EMF	≥ 570 mm

The stated minimum clear opening widths are valid for doorsets with rebated and unrebated door leaf edge. Depending on the official approval respectively the test certificate the minimum dimensions of the door set have to be taken into account.

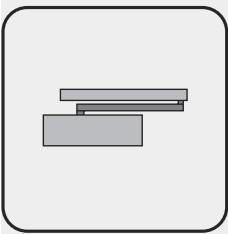

Door closers

14.3

Overhead door closers

Door closer with slide rail, min. dimensions for 2-leaf doors

Standard installation

Unrebated door leaf edge pull side

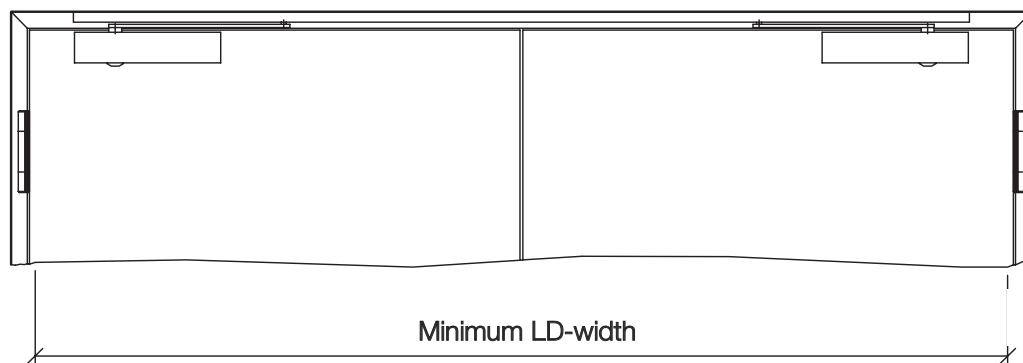

Wooden special doors

Type of the door closer GF: active leaf SF: inactive leaf	LD-width with integrated door coordination in continous slide rail	Inactive leaf width Door leaf edge Unrebated (S) Rebated (F)
GEZE TS 5500-IS	≥ 1134 mm	≥ 398 mm ¹⁾ (S) ≥ 411 mm (F)
GEZE TS 5500 E-IS/G	≥ 1134 mm	
GEZE TS 5500 E-IS	≥ 1134 mm	
GEZE TS 5500 R-IS/G	≥ 1384 mm	
GEZE TS 5500 R-IS	≥ 1384 mm	
DORMA TS 93 GSR	≥ 1154 mm	≥ 360 mm (S) ≥ 373 mm (F)
DORMA TS 93 GSR EMF 1 G	≥ 1154 mm	
DORMA TS 93 GSR EMF 1	≥ 1154 mm	
DORMA TS 93 GSR EMF 2	≥ 1154 mm	
DORMA TS 93 GSR EMR 1 G	≥ 1634 mm	
DORMA TS 93 GSR EMR 1	≥ 1634 mm	
DORMA TS 93 GSR EMR 2	≥ 1634 mm	≥ 360 mm (S) ≥ 373 mm (F)
DORMA GF: TS 99 FL SF: TS 93 GSR	≥ 1154 mm	
DORMA GF: TS 99 FL SF: TS 93 GSR EMF 1	≥ 1154 mm	
DORMA GF: TS 99 FL SF: TS 93 GSR EMR 1	≥ 1634 mm	

¹⁾ If the GEZE protective cap is omitted, it is possible to decrease the width of the inactive leaf by 7 mm.

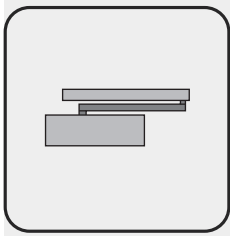

Concealed door closers

Technical terms

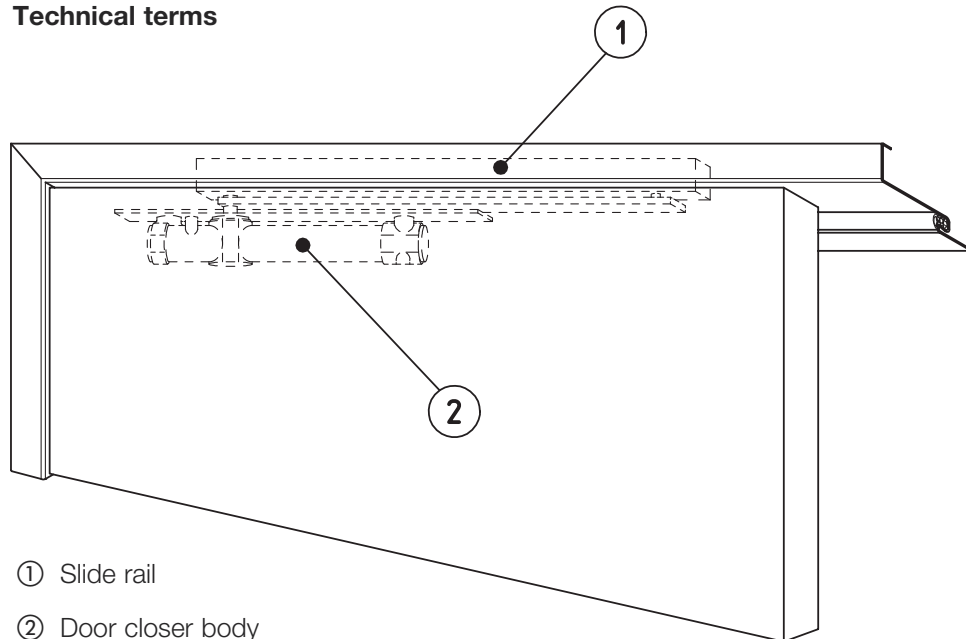

- ① Slide rail
- ② Door closer body

Equipment

On request all 1- and 2-leaf Schörghuber Fire- and Smoke-Protection-Doors are available with concealed door closer with slide rail. The installation is permitted for steel and wooden frames and solid wooden frames, as well as in rebated and unrebated door leaves. The door sets can also be equipped with top panel or transom and fanlight.

Advantage

Everywhere where door sets are supposed to make a creative impression, the concealed door closer is recommended. This modern door fitting with the function and the advantages of a door closer with slide rail is embedded in the door leaf, respectively the door frame. It is not visible if the door is shut.

Therefore the unauthorised manipulation or damaging of the door closer is, to a large extend, precluded.

The concealed high-quality door closer offers the operating comfort of a normal door closer and a great range of functions and the adjustability of the closing pressure, the closing speed, the shock absorbing action and if necessary of an electromechanical hold-open device in the area of 80° and 110°. The DORMA ITS 96 is furthermore equipped with an opening damping action.

Schörghuber service

Schörghuber offers its customers a special service for the installation of the concealed door closer, which is especially extensive for 2-leaf door sets:

- The door closers are mounted within the door leaf.
- The slide rails are mounted within wooden frames, solid wooden frames and top panels. The on site installation of slide rails in steel frames is simplified by the mounting of dimensionally accurate wall protection boxes.
- For 2-leaf door sets, the door coordination of the DORMA ITS GSR is factory-mounted.

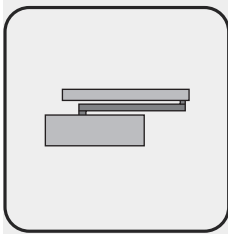

Door closers

Concealed door closers

14.4

Wooden special doors

Function overview

Type of the door closer	Adjust. closing pressure acc. to DIN EN 1154	Adjustable closing speed	Shock absorbing action	Adjustable opening damping action	Adjustable closing time delay	Electromechanical hold-open device approx.	Smoke switch	Door coordination in the concealed in the integrated slide rail
1-leaf door set								
DORMA ITS 96	2 - 4	x	x					
DORMA ITS 96	3 - 6	x	x					
DORMA ITS 96 EMF	2 - 4	x	x			80 - 110°	x ¹⁾	
DORMA ITS 96 EMF	3 - 6 ²⁾	x	x			80 - 110°	x ¹⁾	
GEZE Boxer	2 - 4	x	x	x				
GEZE Boxer	3 - 6	x	x	x				
GEZE Boxer E	2 - 4	x	x	x		80 - 110°	x ¹⁾	
GEZE Boxer E	3 - 6	x	x	x		80 - 110°	x ¹⁾	
2-leaf door set								
DORMA ITS 96 GSR	2 - 4	x	x					x
DORMA ITS 96 GSR	3 - 6	x	x					x
DORMA ITS 96 GSR EMF	2 - 4	x	x			80 - 110°	x ¹⁾	x
DORMA ITS 96 GSR EMF	3 - 6 ²⁾	x	x			80 - 110°	x ¹⁾	x
GEZE Boxer ISM	2 - 4	x	x	x				x
GEZE Boxer ISM	3 - 6	x	x	x				x
GEZE Boxer E-ISM	2 - 4	x	x	x		80 - 110°	x ¹⁾	x
GEZE Boxer E-ISM	3 - 6	x	x	x		80 - 110°	x ¹⁾	x

¹⁾ Only with external smoke switch (DORMA RMZ-K / GEZE RSZ 6)

²⁾ EMF: max. TAB 1250 mm

EN 2-4: max. door leaf width (door rebate dimension) = 1100 mm
max. door leaf weight = 100 kg

EN 3-6: max. door leaf width (door rebate dimension) = 1400 mm²⁾
max. door leaf weight = 180 kg

The aperture angle is, due to the door closer position within the frame rebate, limited to approximately 110°.

If concealed door closers are used in combination with steel frames, the wall opening height has to be extended by 10 mm (BR-height + 10 mm).

If ITS-door closers with electromechanical hold-open device and/or door coordination are used in combination with steel and wooden wrap-around frames, the wall opening height has to be extended by 20 mm. (BR-height + 20 mm)

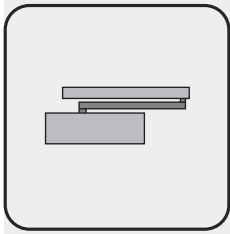

Door closers

14.4

Concealed door closers

Wooden special doors

Concealed installation in steel frame

Rebate width on top and side 15 mm

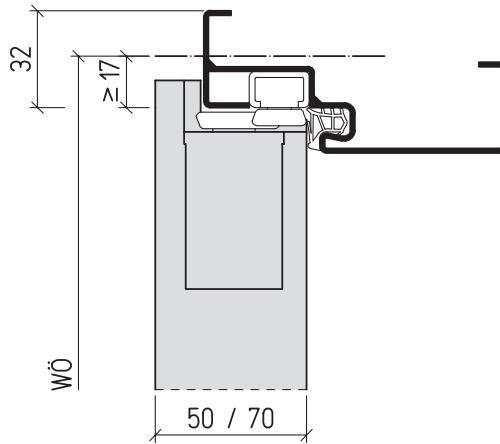

Rebated door leaf edge, similar to unrebated door leaf edge / unrebated with jamb rebate.

Face width 1-leaf door set:

DORMA ITS 96 ≥ 32 mm

GEZE Boxer ≥ 32 mm

Concealed installation in steel frame

Rebate width on top and side 15 mm

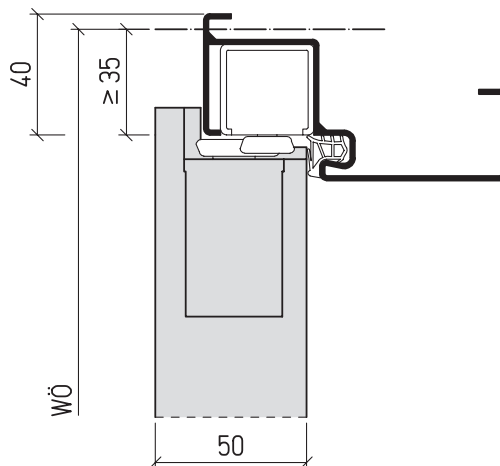

Rebated door leaf edge, similar to unrebated door leaf edge.

Face width 1-leaf door set:

DORMA ITS 96 EMF ≥ 32 mm

GEZE Boxer E ≥ 32 mm

Face width 2-leaf door set:

DORMA ITS 96 GSR ≥ 40 mm

DORMA ITS 96 GSR EMF ≥ 40 mm

GEZE Boxer ISM ≥ 40 mm

GEZE Boxer ISM E-ISM ≥ 40 mm

Concealed installation in steel frame

Rebate width on top and side 15 mm

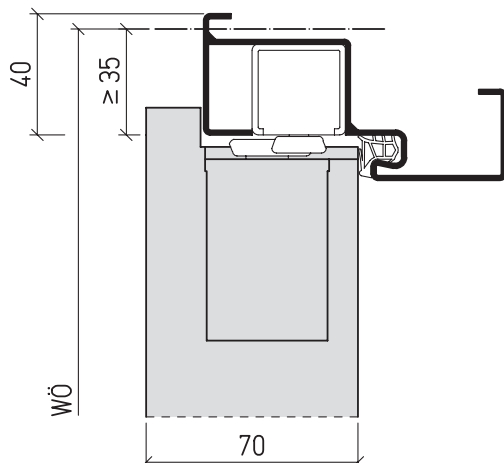

Rebated door leaf edge, also possible for unrebated door leaves with jamb rebate.

Face width 1-leaf door set:

DORMA ITS 96 EMF ≥ 32 mm

GEZE Boxer E ≥ 32 mm

Face width 2-leaf door set:

DORMA ITS 96 GSR ≥ 40 mm

DORMA ITS 96 GSR EMF ≥ 40 mm

GEZE Boxer ISM ≥ 40 mm

GEZE Boxer ISM E-ISM ≥ 40 mm

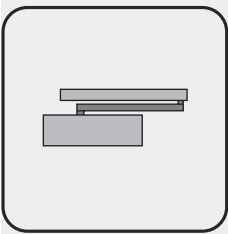

Concealed door closers

Wooden special doors

Concealed installation in wooden wrap-around frame

Rebate width on top and side 15 mm

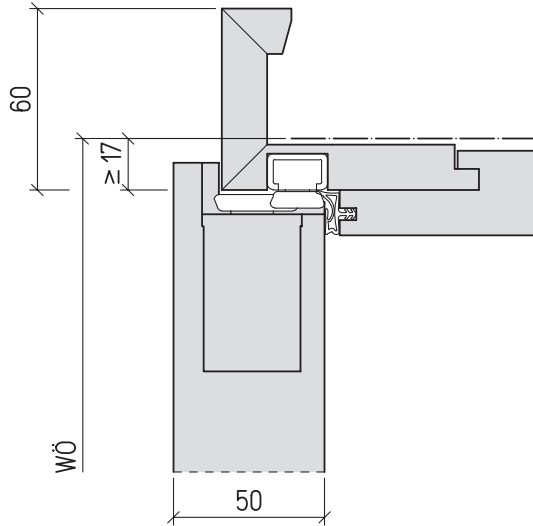

Rebated door leaf edge

Concealed installation in wooden wrap-around frame

Rebate width on top and side 15 mm

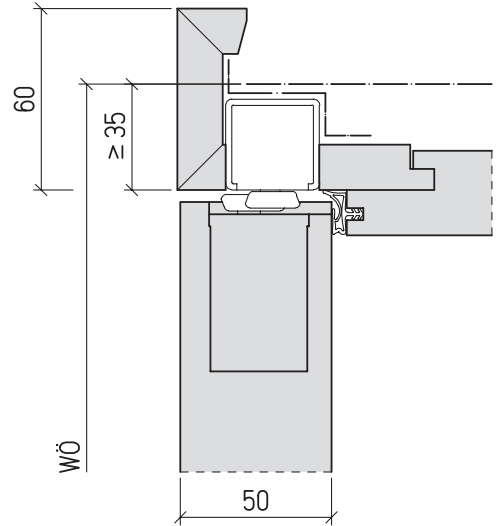

Unrebated door leaf edge

Concealed installation in wooden block frame

Rebate width on top and side 15 mm

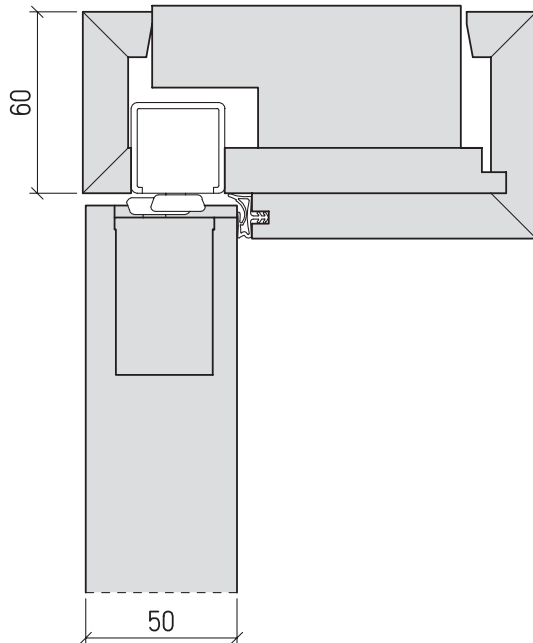

Unrebated door leaf edge, similar to rebated door leaf edge.

Concealed installation in solid wooden frame

Rebate width on top and side 15 mm

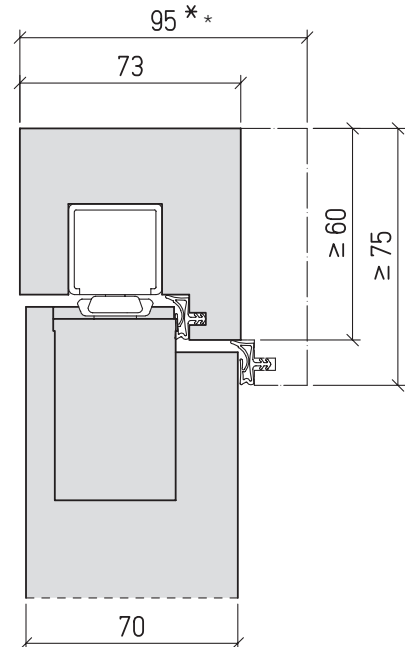

Unrebated door leaf edge with jamb rebate for 70 mm or 73 mm thick doors. Solid wooden frame width $\geq 60 / 73$ mm.

Necessary architrave width:

ITS 96	≥ 35 mm / T90 ≥ 45 mm
ITS 96 EMF	≥ 40 mm / T90 ≥ 45 mm
ITS 96 GSR	T90/T30 ≥ 45 mm / RS ≥ 40 mm / Objekt ≥ 40 mm
ITS 96 GSR EMF	T90/T30 ≥ 45 mm / RS ≥ 40 mm / Objekt ≥ 40 mm

* for higher Sound-Isulation, starting at $R_{w,P} 37$ dB

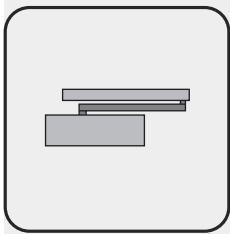

Door closers

14.4

Concealed door closer

With free-swing function

NEW

Schörghuber exclusively offers an innovative door closer type 'FORM-EFS-I' with free-swing function. This door closer combines the advantages of a free-door closer with the visual reevaluation of a concealed door closer. Free-swing function means that the operator of the door is able to operate the door in pull and push direction without any resistance.

the free-wing function is activated by a one-time opening of the door (e.g. in the morning). Hereby the closing pressure of the door closer is mechanically stored. In the event of a fire or a blackout the energy is released again and the door closes automatically.

Rebated door leaf edge

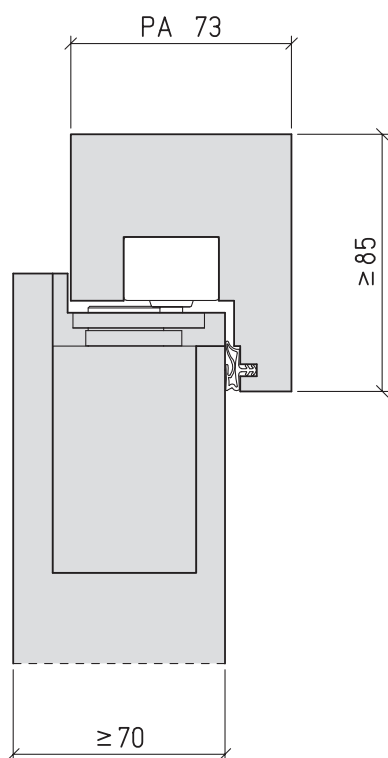

Unrebated door leaf edge with jamb rebate

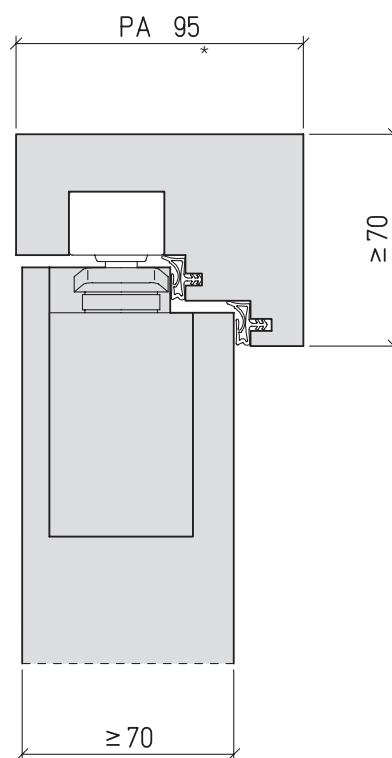

On request with:

- steel frame
- Wooden wrap-around frame
- Wooden block frame
- Special installation: transom installation

Frame rebate vertically 15 mm, top horizontally 30 mm

Take space for slide rail in the height of steel and wooden wrap-around frames into account.

1-leaf door: wall opening = BR + 10 mm and wall opening height + 5 mm

2-leaf door: wall opening = BR + 20 mm and wall opening height + 15 mm

Wooden special doors

Door closers

Concealed door closer

With free-swing function

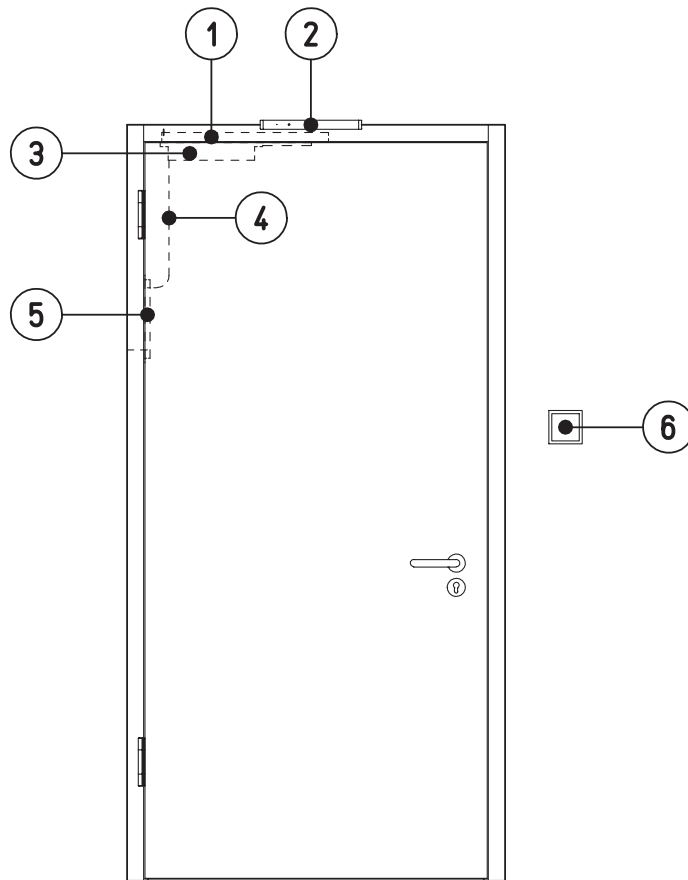

- ① Slide rail
- ② Smoke switch control unit
- ③ Door closer body
- ④ Concealed cable inlet in the door leaf
- ⑤ Concealed cable transition
- ⑥ Breaker switch

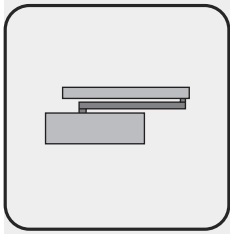

Door closers

14.4

Concealed door closer

With free-swing function

Function overview

Field of application	T 30 / RS / T 90 (Typ 91 N / 92 N) 1- and 2-leaf doors
Closing force	EN 2 – 5
Closing speed	adjustable
Shock absorbing action	adjustable
Aperture angle	ca. 120° (rebated), ca. 130° (unrebated)
Door leaf weight	maximum of 170 kg for a door leaf width of 1250 mm
Maximum door leaf width	1250 mm
Minimum door leaf width	560 mm

Equipment

Power supply	24 V DC, factory-equipped connection cable, concealed in the door leaf, cable transition in the door rebate.
Smoke switch control unit	RSZ 6 or RSZ 5 (provided by customer, available for an additional charge).
Smoke switch	RS 6 or RS 5 (provided by customer, available for an additional charge).
Breaker switch	Necessary, on site effort
Door stop	Might be necessary according to mounting situation

Wooden special doors

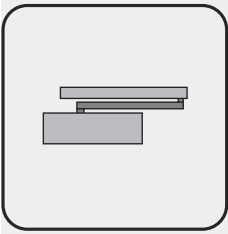

Floor-mounted door closer Configurations

Equipment

As an alternative to overhead door closers Schörghuber offers floor-mounted door closer (BTS) for 1- and 2-leaf Fire- and Smoke-Protection-Doors in various configurations for all frame versions.

- BTS with pivot hinges, the door hinges are dispensed (not for T 90)
- BTS with attached slide rail and with door hinges
- BTS with integrated slide rail and door hinges

The space needed in the floor for the door closers, its protective box (cement box) and mounting rail with the frame is at least 65 mm between unfinished floor and surface finished floor (OFF). The floor recess of the frame has to be at least ≥ 45 mm. The cement box has to be, according to manufacturer instructions, mounted within a layer of mortar and so be firmly attached to the unfinished floor.

Advantage

The advantage of the floor-mounted door closer is the high bearing force and therefore the reliability of the system. Furthermore, due to the multiple functions, the visual appearance of the door set is not disturbed, because the door closer is embedded in the floor.

The opening of the door is not hindered by projecting parts of the door closer, therefore, under consideration of the handles, an aperture angle and hold-open angle of 180° is possible.

➔ Chapter dimensions

The standard equipment of the floor-mounted door closer usually includes the adjustability of the closing pressure (except DORMA BTS 80), the closing speed and the shock absorbing action. The cover plates of the floor-mounted door closers are by default made of stainless steel.

The protective caps of the pivot hinges are made of anodised light metal or matched in colour to the cover plates.

Floor-mounted door closer for continuous floor covering

Rebated door leaf edge

Example with attached slide rail

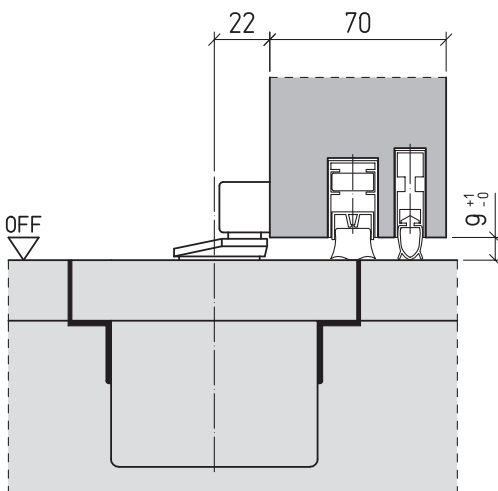

Unrebated door leaf edge or unrebated with jamb rebate

Example with pivot hinges

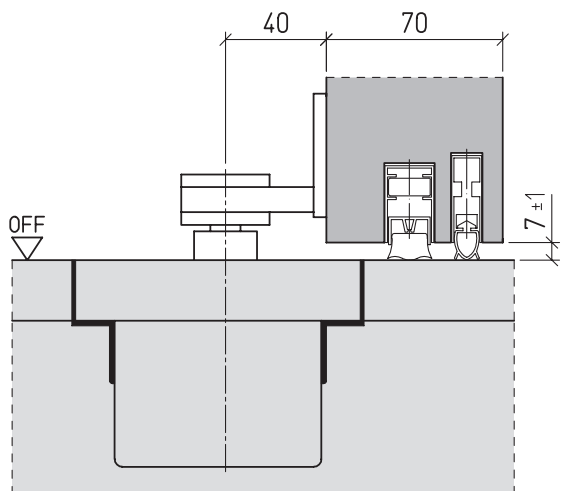

Another advantage of this version, which can be equipped with all of the configurations mentioned above, is the additional optical revaluation due to the possibility to lay the floor covering (stone, parquet, carpet etc.) continuously.

The standard cover plate is replaced with a segment of the floor covering, which is pre-assembled in an angular frame made of stainless steel.

Depending on the equipment of a door set with floor-mounted door closer the sound-insulation function can be slightly lowered.

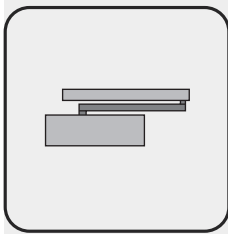

Door closers

14.5

Floor-mounted door closer

Configurations

Function overview

Type of the door closer	Adjust. closing pressure acc. to DIN EN 1154	Adjustable closing speed	Shock absorbing action	Opening damping action (not adjustable)	Closing time delay	Electrohydraulic hold-open device	Electromechanic hold-open device approx.	Free-swing function with integrated hold-open device	Concealed door coordination in the floor
1-leaf door sets									
GEZE TS 550 F with pivot hinges	3 - 6	x	x						
GEZE TS 550 F-G in combination with hinges and attached slide rail	3 - 6	x	x						
GEZE TS 550 F-G in combination with hinges and integrated slide rail	3 - 6	x	x						
GEZE TS 550 E with pivot hinges	3 - 6	x	x				80-180°		
GEZE TS 550 E-G in combination with hinges and attached slide rail	3 - 6	x	x				80-160°		
GEZE TS 550 E-G in combination with hinges and integrated slide rail	3 - 6	x	x				80-160°		
DORMA BTS 80 F	4/5/6	x	x	x					
DORMA BTS 80 EMB	4/5/6	x	x	x		75-180°			
DORMA BTS 80 FLB	4/5/6	x		x				x	
2-leaf door sets									
GEZE TS 550 IS with pivot bearing	3 - 6	x	x						x
GEZE TS 550 IS in combination with hinges and attached slide rail	3 - 6	x	x						x
GEZE TS 550 IS in combination with hinges and integrated slide rail	3 - 6	x	x						x
GEZE TS 550 E-IS with pivot bearing	3 - 6	x	x				80-180°		x
GEZE TS 550 E-IS in combination with hinges and attached slide rail	3 - 6	x	x				80-150°		x
GEZE TS 550 E-IS in combination with hinges and integrated slide rail	3 - 6	x	x				80-150°		x

The door leaves of 2-leaf door sets equipped with floor-mounted door closers and pivot hinges might get wedged. In order to avoid this effect limitations in the minimum LD-width are possible. ➔ Chapter dimensions

Wooden special doors

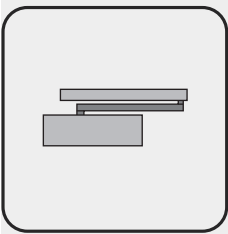

Floor-mounted door closer

Configurations, thickness of door leaf 50 mm

Wooden special doors

Rebated door leaf edge

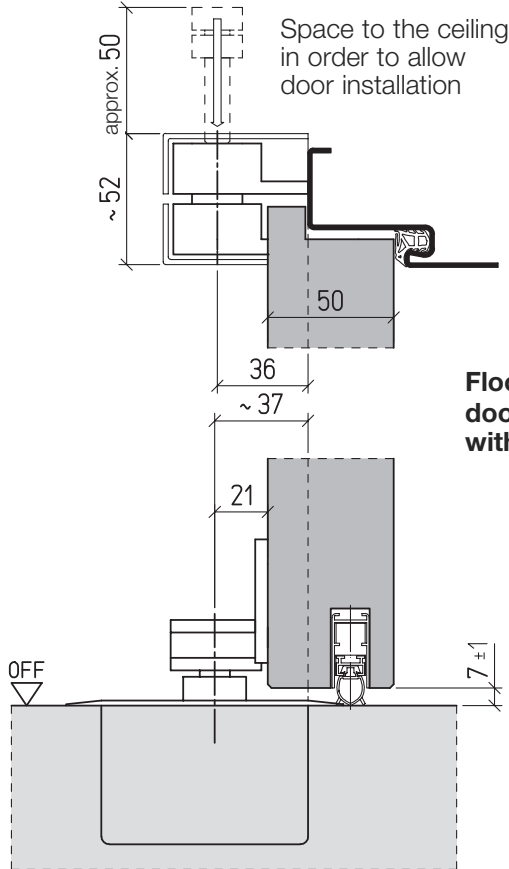

Unrebated door leaf edge

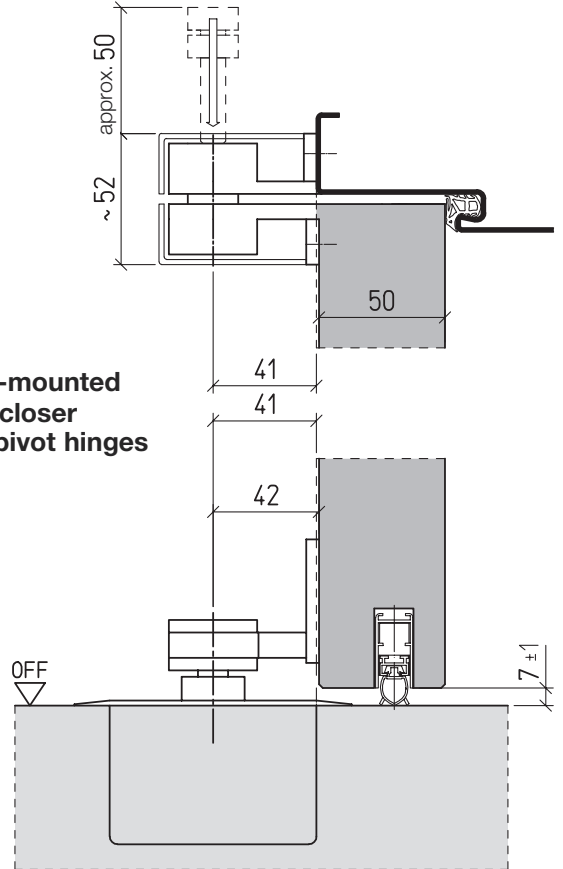

Floor-mounted door closer with pivot hinges

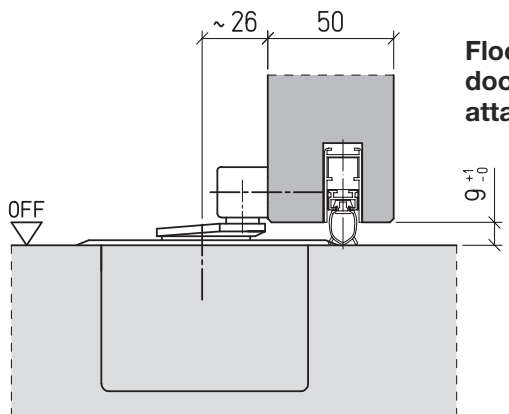

Floor-mounted door closer with attached slide rail

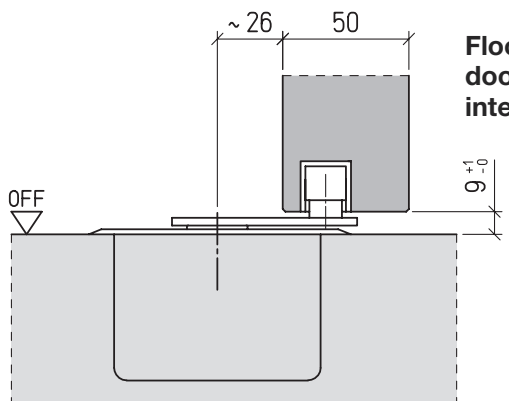
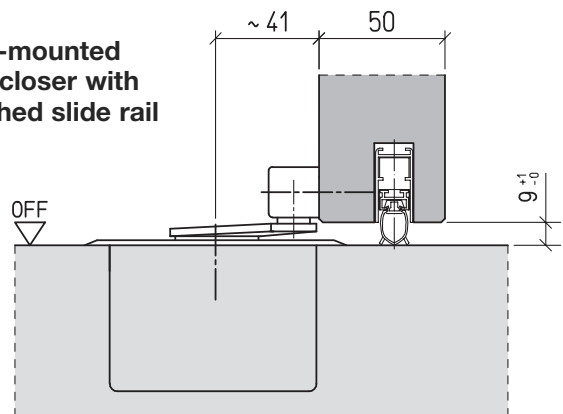

Floor-mounted door closer with integrated slide rail

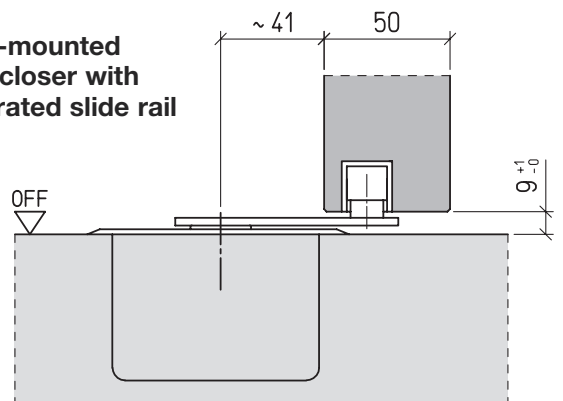

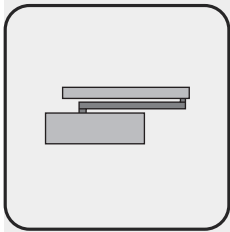

Door closers

14.5

Floor-mounted door closer

Configurations, thickness of door leaf 70 respectively 73 mm

Wooden special doors

Rebated door leaf edge

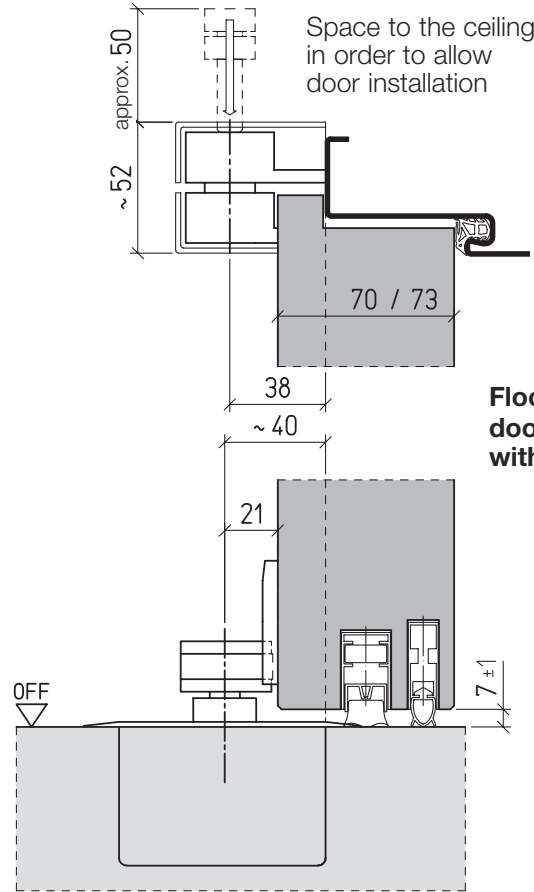

Unrebated door leaf edge with jamb rebate

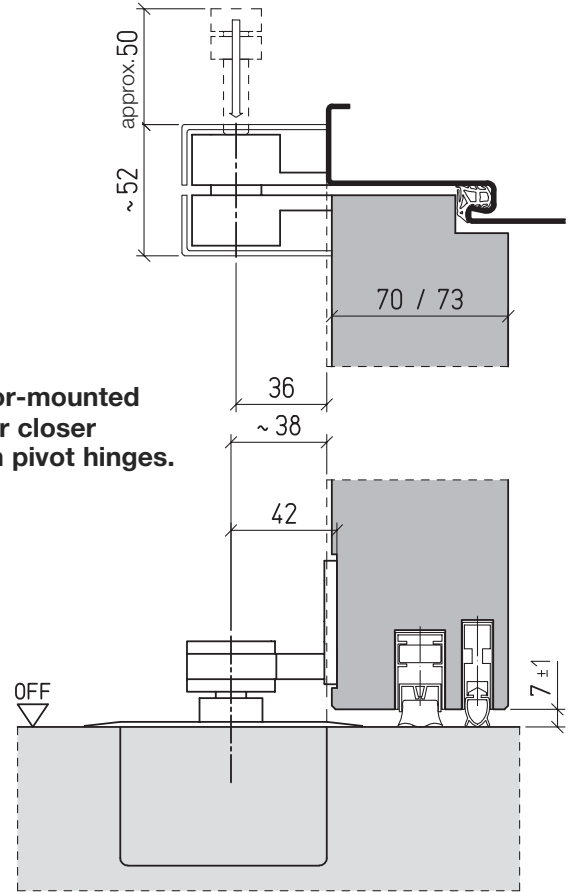

Floor-mounted door closer with pivot hinges.

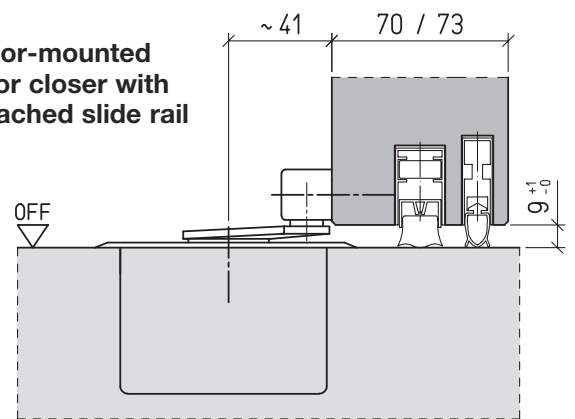
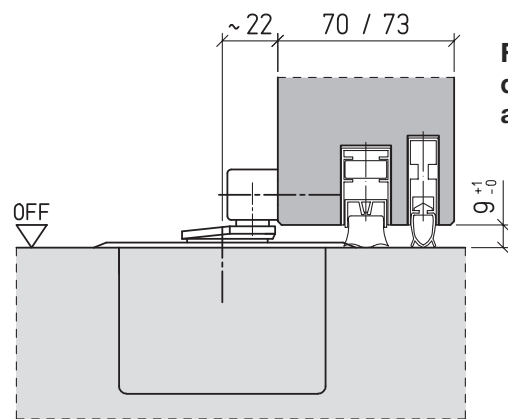

Floor-mounted door closer with attached slide rail

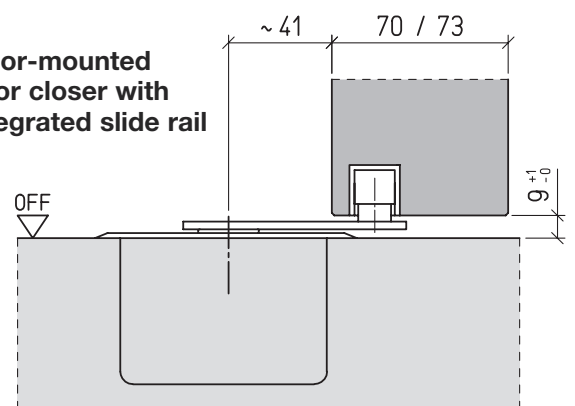
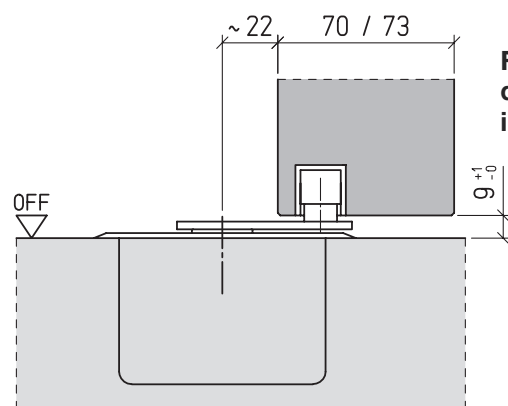

Floor-mounted door closer with integrated slide rail

Door closers

Automatic door operators

Configurations

Pull side

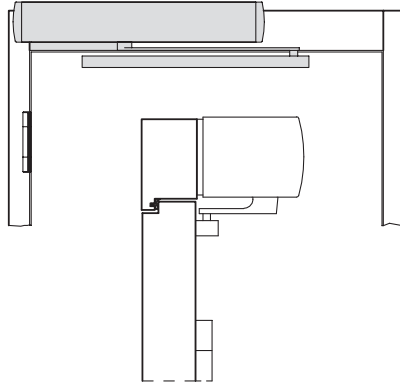

Push side

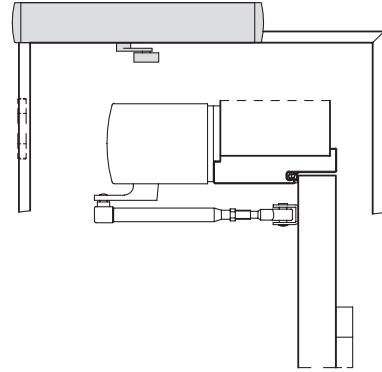
**General information**

Automatic door operators offer a special comfort in operating doors. The door opens automatically as soon as an impulse is triggered. Everywhere where a lot of goods are transported or in areas with a lot of foot traffic, e.g. hospitals, nursing homes, administrations, hotels, restaurants and shopping centres, these door closers are used.

The activation can be triggered contactless by sensors or by e.g. a pushbutton. Additional options are for example the triggering via handle operation or the so called Push and Go function, at which the door is manually opened a couple of degrees and then the automatic opening process is activated by the integrated swing angle scan.

Security

The new standard DIN 18650 centres especially the security of the door users. The most important part of this standard is the realisation of the so called hazard analysis. The required security equipment is coordinated and recorded on site, between user and manufacturer of the door operator. For this purpose please directly contact DORMA (www.dorma.com) respectively GEZE (www.geze.com).

The Schörghuber delivery set:

- Automatic door operator with mounting plate and fastening screws
- Pilot holes on door leaf and frame
- Arms / slide rail depending on model and its design
- Door operator DORMA 447 FS or 117 RS
- Bolt switch contact eff eff 878 (shutdown function if bolt is locked)
- Integrated program switch (for high doors possibly not accessible, therefore if necessary to be added additionally on site)
- Concealed cable channels within a door set if specially ordered

Necessary efforts on site:

- Hazard analysis by the manufacturer of the door operator
- Impulse transmitter (triggering device)
- Sensor rail (security equipment according to the hazard analysis)
- Smoke detector (obtainable on additional charge)
- Take cable channels and electric installations into account
- Filling of the cavities if necessary and upper fixing material
- Emergency stop switch and "door closing switch"
- Initial operation by the manufacturer of the automatic door operator or an authorised personnel

We recommend to coordinate the on site efforts with the responsible planners / crafts.

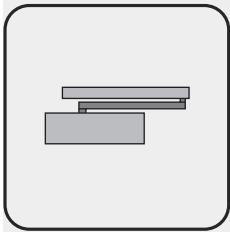

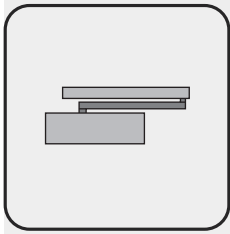

Door closers

14.6

Automatic door operators

Configurations

Equipment examples

Automatic door operator with arms on push side

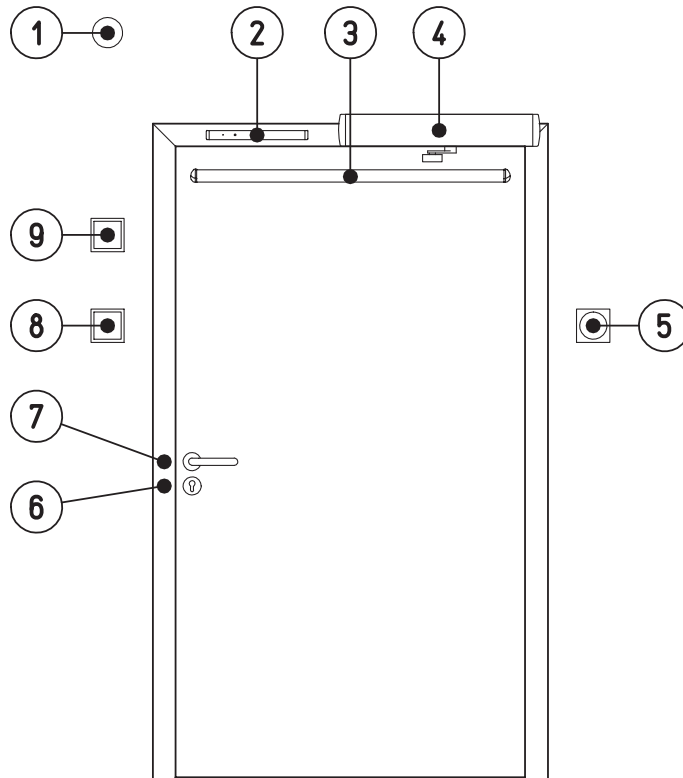

Push side view

- ① On request with additional smoke detector
- ② Smoke switch control unit
- ③ Motion detector / security sensor
- ④ Door operator
- ⑤ Emergency stop switch
- ⑥ Bolt switch contact
- ⑦ Electrical strike
- ⑧ On request with pushbutton
- ⑨ On request with external program switch

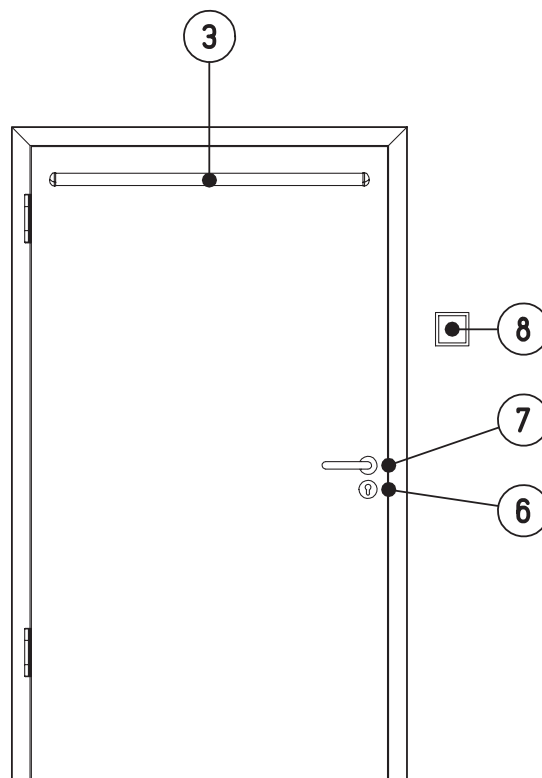

Pull side view

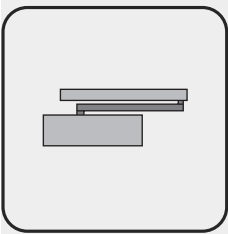

Door closers

14.6

Automatic door operators

Configurations

Equipment examples

Automatic door operator with slide rail on pull side

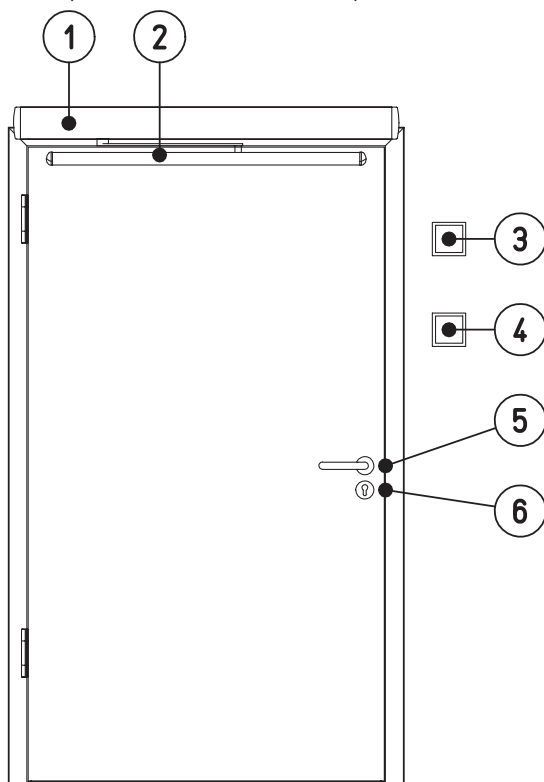

Pull side view

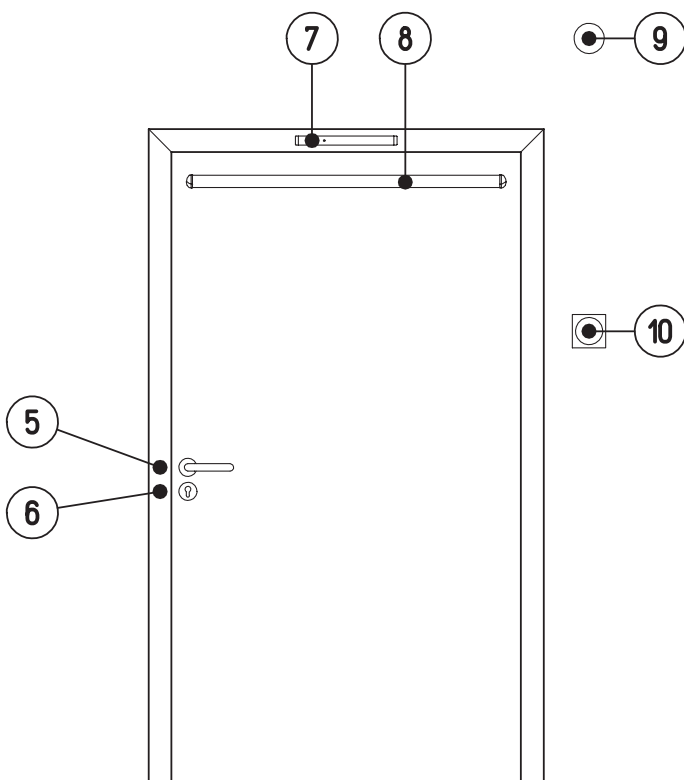

Push side view

- ① Door operator
- ② Slide rail and motion detector / security sensor, on request integrated
- ③ On request with external program switch
- ④ On request with pushbutton
- ⑤ Electrical strike
- ⑥ Bolt switch contact
- ⑦ Smoke switch control unit
- ⑧ Motion detector / security sensor
- ⑨ On request with additional smoke detector
- ⑩ Emergency stop switch

Wooden special doors



Schörhuber

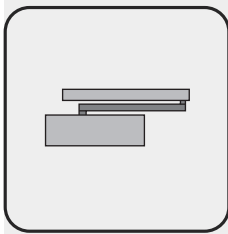

Automatic door operators

Configurations

Function overview

Type of the door operator	Adjust. closing pressure according to EN 1154	Adjustable closing speed	Shock absorbing action	Adjustable hold-open time	Set-up „permanently open“	Adjustable opening damping action	Integrated door coordination	On request with integrated smoke and security sensor
1-leaf door sets								
DORMA ED 200	4 - 6/7	x		x	x	x		
DORMA CD 400	5	x	x	x	x	x		x
GEZE TSA 160 F	3 - 6	x	x	x	x	x		
GEZE SLIMDRIVE SD	2 - 6	x	x	x				
GEZE TSA EMD F	3 - 6	x	x	x	x	x		
2-leaf door sets with an operator for the active leaf								
DORMA ED 200 ESR-1	4 - 6 / 7	x		x	x	x	x	
DORMA ED 200 ESR-1/2 ¹⁾	4 - 6 / 7	x		x	x	x	x	
DORMA CD 400	5	x	x	x	x	x		x
GEZE TSA 160 F-IS/TS	3 - 6	x	x	x	x	x	x	
GEZE Slimdrive SD-IS/TS	2 - 6	x	x	x				
2-leaf door sets with an operator for the active and the inactive leaf								
DORMA ED 200 ESR	4 - 6 / 7	x		x	x	x	x	
DORMA CD 400	5	x	x	x	x	x		x
GEZE TSA 160 F-IS	3 - 6	x	x	x	x	x	x	
GEZE Slimdrive SD-IS	2 - 6	x	x	x				
GEZE Slimdrive EMD F-IS	3 - 5 4 - 6	x	x	x	x	x	x	

¹⁾ with integrated hold-open device on inactive leaf

All Schörghuber 1-leaf doors can be equipped and ordered with an automatic door operator.

Automatic door operators on active and inactive leaf are possible for all Schörghuber 2-leaf doors. For type 4 N, 14 N up to a maximum LD of 2186 x 2218 mm.

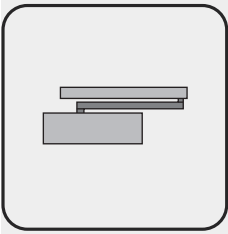

Door closers

14.6

Automatic door operators

Configurations

Possible clear opening widths for 1-leaf doors

Type of the door closer	Installation options	Minimum LD-width ¹⁾	Maximum LD-width ¹⁾
DORMA ED 200	Transom installation BGS	595 mm	1378 mm
DORMA CD 400 Softline	Transom installation BS	708 mm	1228 mm
DORMA CD 400 Softline	Transom installation BGS	728 mm	1228 mm
DORMA CD 400 SSCD	Transom installation BS	755 mm	1228 mm
DORMA CD 400 SSCD	Transom installation BGS	768 mm	1228 mm
GEZE TSA 160 F	Transom installation BGS	668 mm	1378 mm
GEZE SLIMDRIVE SD	Transom installation BS	631 mm	1378 mm
GEZE SLIMDRIVE SD	Transom installation BGS	616 mm	1378 mm
GEZE SLIMDRIVE SD	Standard installation BS	666 mm	1378 mm
GEZE SLIMDRIVE SD	Standard installation BGS	720 mm	1378 mm
GEZE SLIMDRIVE EMD F	Transom installation BS	850 mm	1378 mm
GEZE SLIMDRIVE EMD F	Transom installation BGS	850 mm	1378 mm

¹⁾ frame-dependent approximate values

SSCD = slide rail with integrated sensors: microwave detectors and IR-security detectors

BS = pull side

BGS = push side

Wooden special doors

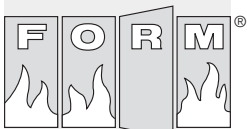

Schörhuber

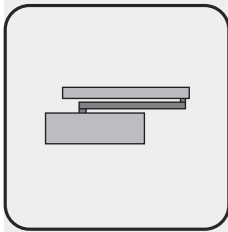

Door closers

14.6

Automatic door operators

Configurations

Possible clear opening widths for 2-leaf doors

Type of the door closer	Installation options	Minimum LD-width ¹⁾	Maximum LD-width ¹⁾
DORMA ED 200 ESR	Transom installation BGS	1224 mm	2784 mm
DORMA ED 200 ESR-1	Transom installation BGS	1224 mm	2784 mm
DORMA ED 200 ESR-1/2	Transom installation BGS	1224 mm	2484 mm
DORMA CD 400 Softline	Transom installation BS	1474 mm	2484 mm
DORMA CD 400 Softline	Transom installation BGS	1484 mm	2484 mm
DORMA CD 400 SSCD	Transom installation BS	1551 mm	2484 mm
DORMA CD 400 SSCD	Transom installation BGS	1564 mm	2784 mm
GEZE TSA 160 F-IS/TS	Transom installation BGS	1194 mm	2734 mm
GEZE TSA 160 F-IS	Transom installation BGS	1404 mm	2734 mm
GEZE Slimdrive SD-IS	Transom installation BS	1500 mm	2700 mm
GEZE Slimdrive SD-IS	Transom installation BGS	1500 mm	2700 mm
GEZE Slimdrive SD-IS	Standard installation BS	1500 mm	2700 mm
GEZE Slimdrive SD-IS/TS	Transom installation BS	1200 mm	2700 mm
GEZE Slimdrive SD-IS/TS	Transom installation BGS	1200 mm	2700 mm
GEZE Slimdrive SD-IS/TS	Standard installation BS	1200 mm	2700 mm
GEZE Slimdrive EMD F-IS	Transom installation BS	1200 mm	2500 mm
GEZE Slimdrive EMD F-IS	Transom installation BGS	1200 mm	2500 mm ²⁾
GEZE Slimdrive EMD F-IS	Standard installation BS	1200 mm	2700 mm

¹⁾ frame-dependent approximate values

²⁾ with arms of 2700 mm

SSCD = slide rail with integrated sensors: microwave detectors and IR-security detectors

BS = pull side

BGS = push side

Wooden special doors

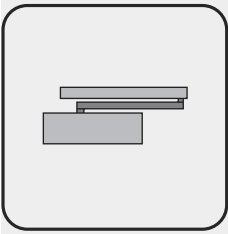

Door closers

14.6

Automatic door operators

Configurations for 2-leaf door sets

Operator for 2-leaf door sets on active leaf

Type of the door closer	Equipment active leaf	Equipment inactive leaf
DORMA ED 200 ESR-1	ED 200 ESR-1 with continuous casing in transom installation on BGS Integrated door coordination	
DORMA CD 400	CD 400 in transom installation on BS Pivot bearing on BGS Door coordination in GSR-slide rail on BGS	TS 93 on BGS
DORMA CD 400	CD 400 in transom installation on BGS Pivot bearing on BS Door coordination in GSR-slide rail on BS	TS 93 on BS
GEZE TSA 160 F-IS/TS	TSA 160 F-IS/TS with continuous casing in transom installation on BGS Integrated door coordination	
GEZE Slimdrive SD-IS/TS	Slimdrive SD-IS/TS with continuous casing in transom installation on BS or BGS Integrated door coordination	

BS = pull side
BGS = push side

Wooden special doors

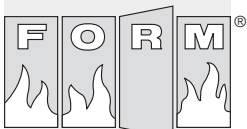

Schörghuber

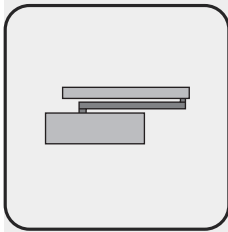

Door closers

14.6

Automatic door operators

Configurations for 2-leaf door sets

Operator for 2-leaf door sets on active and inactive leaf

Type of the door closer	Equipment active leaf	Equipment inactive leaf
DORMA ED 200 ESR	ED 200 ESR with continuous casing in transom installation on BGS Integrated door coordination	
DORMA CD 400	CD 400 in transom installation on BS Pivot bearing on BGS Door coordination in GSR-slide rail on BGS	CD 400 in transom installation on BGS Pivot bearing on BGS
DORMA CD 400	CD 400 in transom installation on BGS Pivot bearing on BS Door coordination in GSR-slide rail on BS	CD 400 in transom installation on BGS Pivot bearing on BS
GEZE TSA 160 F-IS	TSA 160 F-IS with continuous casing in transom installation on BGS Integrated door coordination	
GEZE Slimdrive SD-IS	Slimdrive SD-IS with continuous casing in transom installation on BS or BGS Integrated door coordination	
GEZE Slimdrive SD-IS	Slimdrive in Standard installation on BS Integrated door coordination in slide rail	Slimdrive in Standard installation on BS
GEZE Slimdrive EMD F-IS	Slimdrive EMD F-IS with continuous casing in transom installation on BS or BGS Integrated door coordination	
GEZE Slimdrive EMD F-IS	Slimdrive in Standard installation on BS Integrated door coordination in slide rail	Slimdrive in Standard installation on BS

BS = pull side
BGS = push side

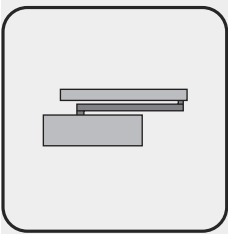

Automatic door operators

Installation options for DORMA ED 200 / GEZE TSA 160 F

Wooden special doors

Door set with steel wrap-around frame

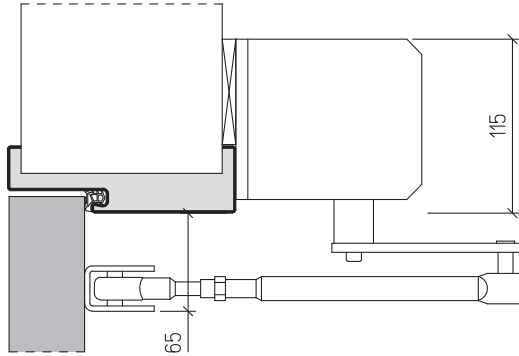

Door set with solid wooden frame

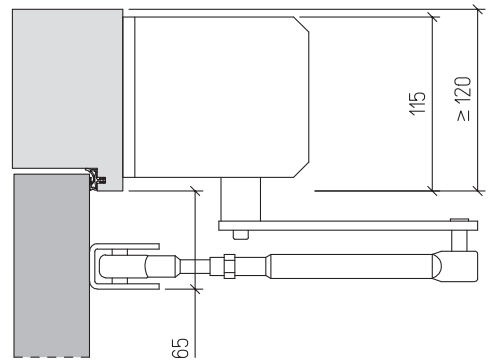

Door set with wooden wrap-around frame

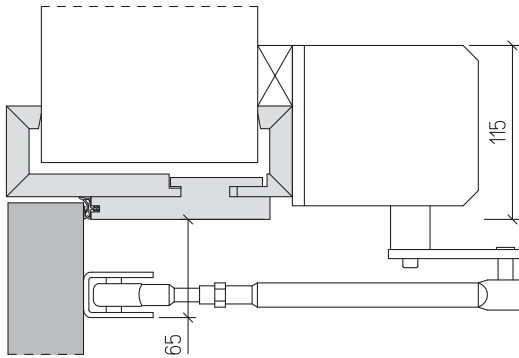

Door set with top panel

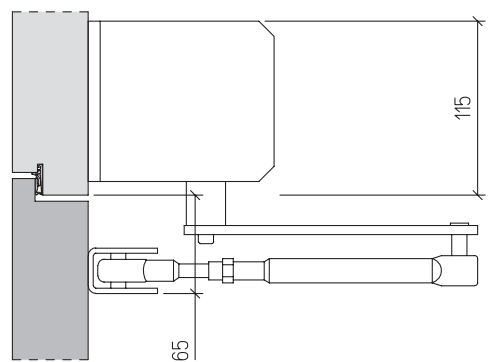

Door set with wooden block frame

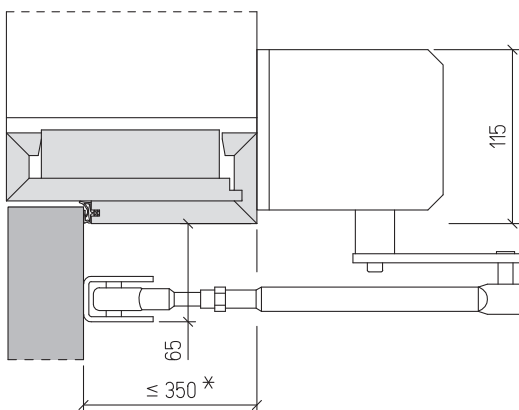

Door set in gypsum plasterboard wall

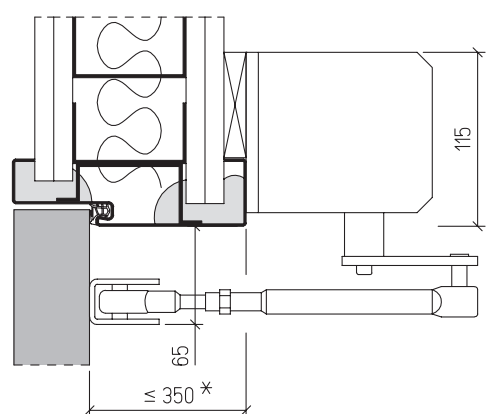

* possible transom widths
 DORMA ≤ 500 mm
 GEZE ≤ 350 mm

Unrebated door leaf edge, similar to unrebated door leaf edge with jamb rebate or rebated door leaf edge

For the installation in gypsum plasterboard walls the following instructions are compulsory:

- On site reinforcement of the upper horizontal connections with two u-profiles, thickness 2 mm
- Sheet thickness of steel frames 2 mm

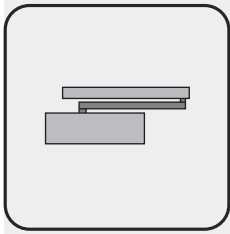

Door closers

14.6

Automatic door operators

Installation options for DORMA CD 400

Transom installation

Pull side, with SSCD*-slide rail

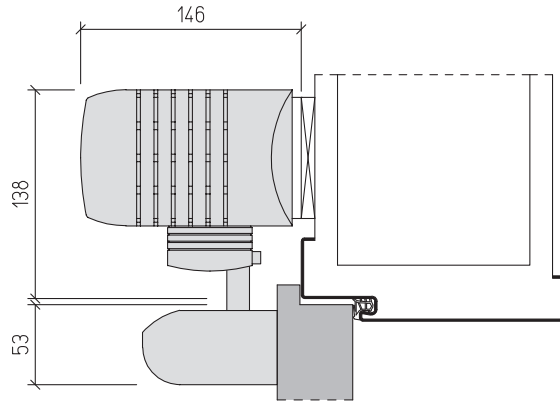

Transom installation

Push side, with SSCD*-slide rail

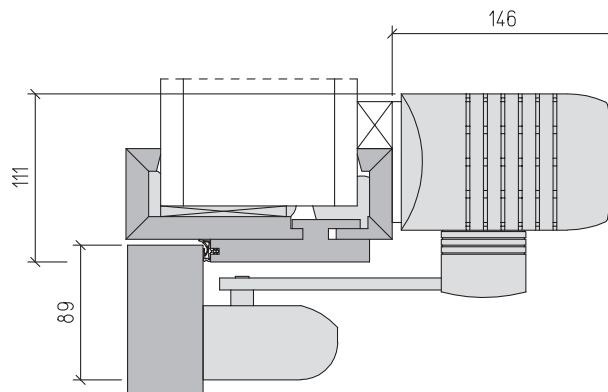

Transom installation

Pull side, with SSCD*-slide rail

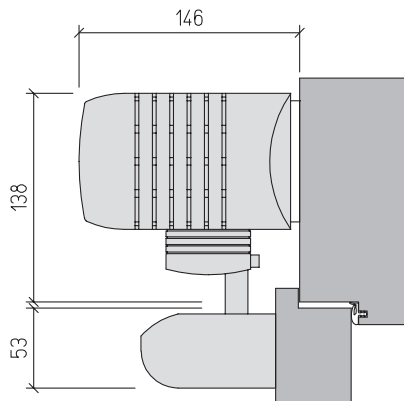

* integrated sensors: smoke detectors and IR-security detectors

Wooden special doors

Door closers

Automatic door operators

Installation options for DORMA CD 400

Transom installation

Push side, with Softline-slide rail

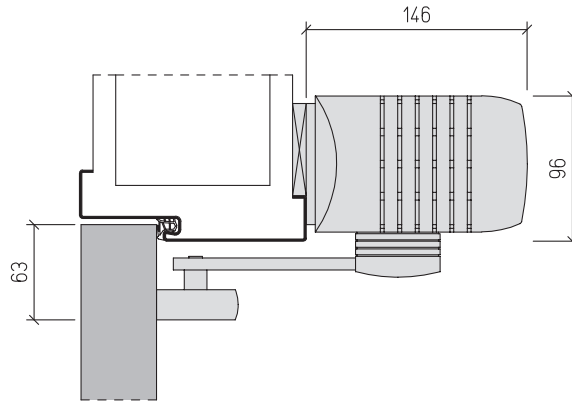

Transom installation

Pull side, with Softline-slide rail

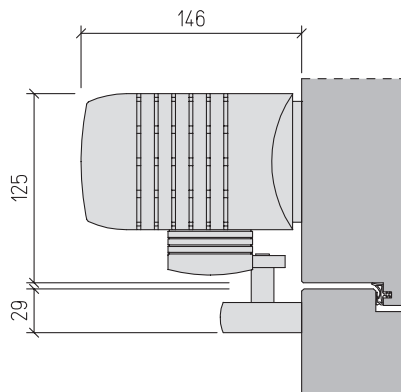

Transom installation

Push side, with Softline-slide rail

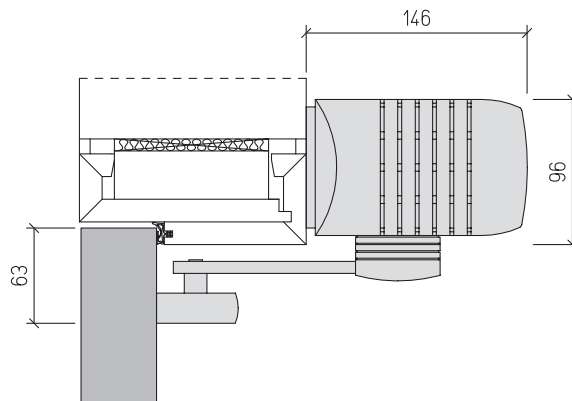

Wooden special doors

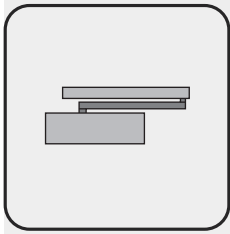

Door closers

14.6

Automatic door operators

Installation options for GEZE SLIMDRIVE SD

Standard installation

Pull side, rebated door leaf edge

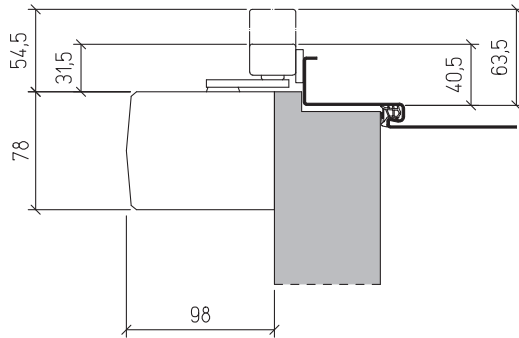

Transom installation

Pull side, unrebrated door leaf edge

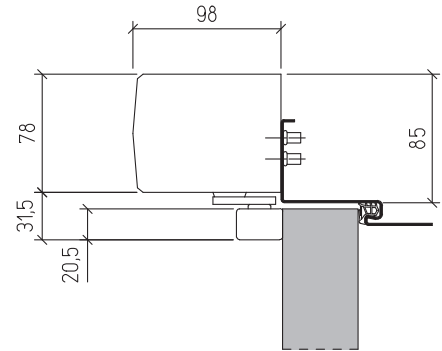

Standard installation

Push side, counter rebated door leaf edge

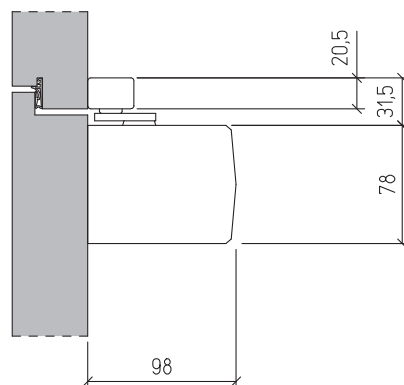

Standard installation with bracket for transom installation

Push side, standard installation

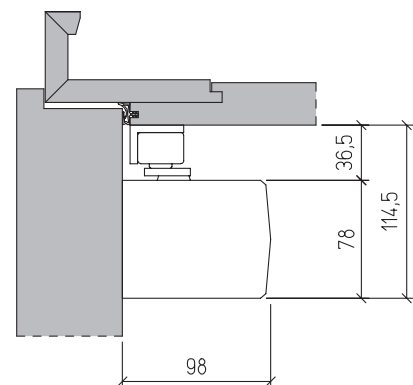

In connection with a top panel

Rebrated door leaf edge, similar to unrebrated door leaf edge, unrebrated with rebated or double-jamb rebate.

Take the necessary frieze width for vision panels into account.

Wooden special doors

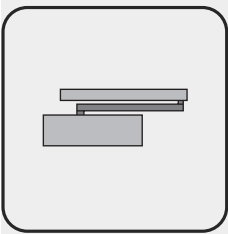

Door closers

14.6

Automatic door operators

Installation options for GEZE SLIMDRIVE EMD

Wooden special doors

Transom installation

Pull side with slide rail

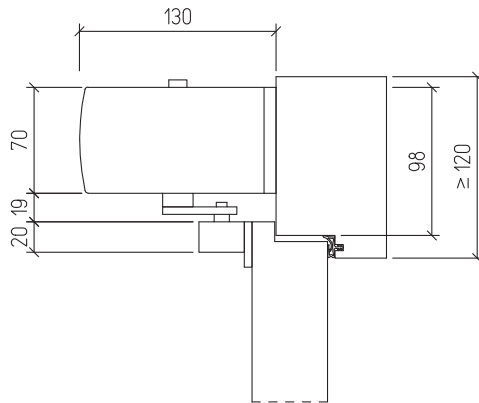

Transom installation

Push side with arms

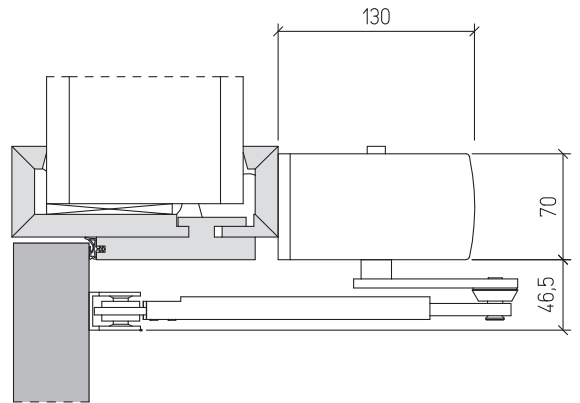

Transom installation

Pull side with slide rail

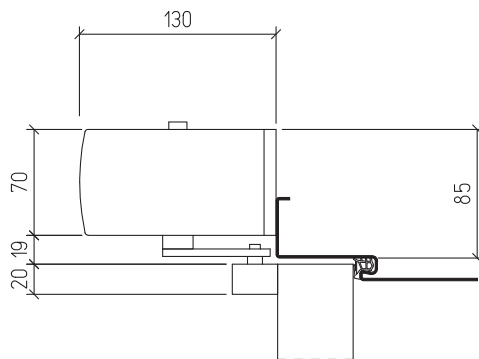

Transom installation

Push side with slide rail

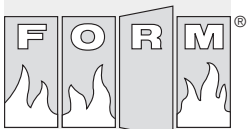
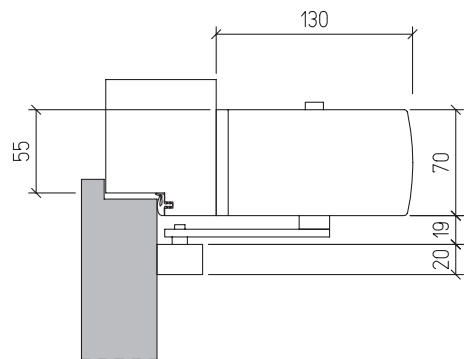

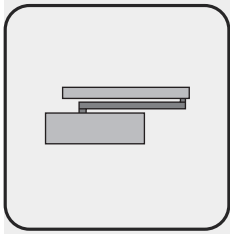

Door closers

14.7

Overhead door closers

For smoke and heat venting systems

During the event of a fire smoke gases as well as heat energies evolve, which can, due to the thermal lift, fill the room or building completely within a short period of time. These toxic gases and the heat emission represent a great danger for escaping persons as well as for rescue personnel and need to be deaerated as fast as possible.

System solution with overhead door closer

For a smoke and heat venting system (SHEV) the following components are required:

- ① Smoke and heat switches
- ② Suitable door closer for a SHEV
- ③ Electromagnet, for small door sets on request with electrical strike, 24 V DC with electric torque pulsed voltage
- ④ Control unit
- ⑤ Emergency power supply
- ⑥ Pushbutton

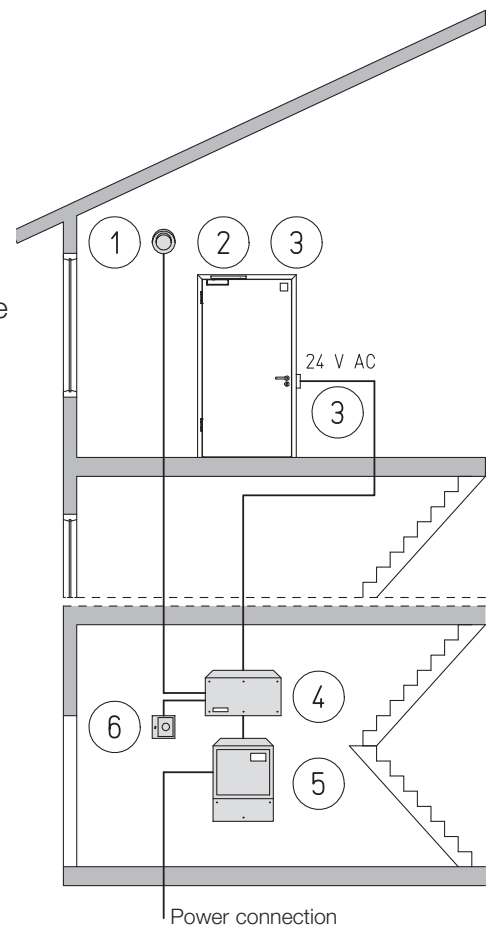

Wooden special doors

Door closers

Overhead door closers

For smoke and heat venting systems

System solution with automatic door operator

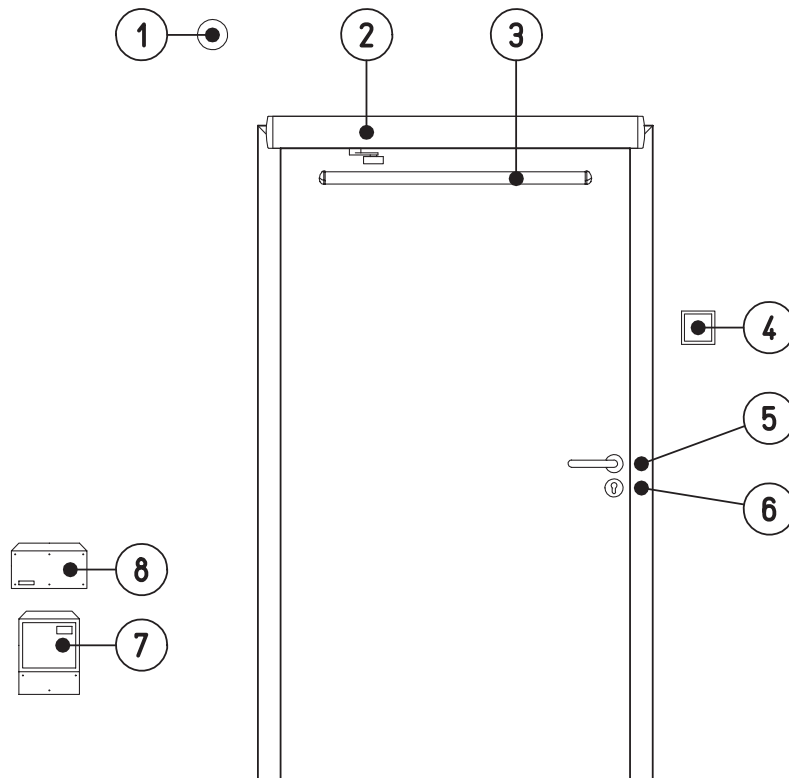

- ① Smoke and heat switches
- ② Automatic door operator
- ③ Motion detector / security sensor
- ④ Pushbutton
- ⑤ Electrical strike
- ⑥ Bolt switch contact
- ⑦ Control unit
- ⑧ Emergency power supply

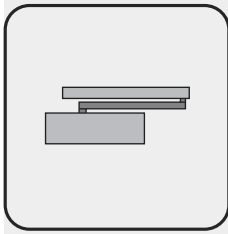

Door closers

14.7

Overhead door closers

For smoke and heat venting systems

Functional description

Opening of the door

Manual:

- By operating a pushbutton or other impulse transmitter the door opener is released. The door closer, under spring tension, opens the door.
- By operating the door handles the door can also be opened without activating the smoke and heat exhaust vent system.

Automatic:

- By activating the smoke and heat switches the impulse is transmitted to the the door opener and it releases the door.
- Door aperture angles are limited to approximately 90° (otherwise the door closer could possibly be damaged).

Closing of the door

- The operated pushbutton and/or the smoke and heat switches have to be reset. Afterwards the door has to be pushed shut by hand, against the pressure of the door closer, which is used as a door opener.

If the power supply system of the building is not equipped with an emergency power supply, the SHEV system must be connected to an emergency power supply.

The door can not be closed by using the SHEV system, therefore the SHEV system is not suitable for aerating the building.

During the on site planning of a SHEV system, the possible pressure differences on the two sides of the door leaf have to be taken into account. These parameters are determining for the choice of the door closer.

Door closers

Overhead door closers

For smoke and heat venting systems

SHEV-door closer

Type of the door closer	Standard instal.		Transom installation	
	BS	BGS	BS	BGS
TS 4000 with slide rail		●	●	
TS 4000 G with slide rail	●			●
TS 5000		●	●	
TS 5000 L	●			●
TS 93		●	●	
TS 93 G	●			●

BS = pull side
BGS = push side

Additional door closers e.g. OTS with hold-open or free-swing function as well as automatic door operators for SHEV systems are available on request.

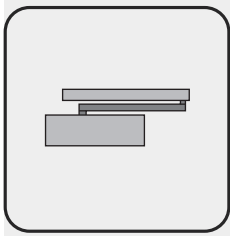

Door closers

Hold-open devices

Regulations

Functions

The self-closing function of Fire- and Smoke-Protection-Doors is added by suitable and approved door closers. The use of buildings makes it sometimes necessary to keep doors open for a certain period of time (e.g. transportation of goods)

In order to hold-open Fire- and Smoke-Protection-Doors, approved hold-open devices are necessary. These are either integrated in the door closer (door closers with hold-open function) or external devices (electromagnet ➔ chapter 14.15) which hinder the closing operation. The hold-open device is turned off in order to release the closing operation either by the smoke switch control unit in the event of a fire, or by a blackout or by manual release.

Hold-open devices are regulated in the DIN EN 1155.

Excerpts of the guidelines for hold-open devices

Hold-open devices

Hold-open devices are devices, or combinations of them, which are suitable for the need of a controlled stopping of the closing function. If the event of a fire or other triggers of the self-closing function, the integrated release mechanism enables open doors to close.

A hold-open device consists of at least one fire detector, a release mechanism, a hold-open device and a power supply.

Fire detector

Fire detectors are the parts of a hold-open device, which constantly, or in defined periods of time, measure a suitable physical or chemical parameter in order to detect a fire in the monitored area and signal it to the release mechanism.

Release mechanisms

The release mechanism processes the signals of the fire detectors and, if a fire detection parameter threshold level is exceeded, turns off the connected hold-open device.

Hold-open mechanisms

Hold-open mechanisms are mechanisms which hold back the necessary energy to close the door.

Common hold-open devices are electromagnetic systems such as electromagnets, magnetic valves and magnetic coupler.

Power supplies

The power supply provides electricity for the fire detectors (24 volt), the release mechanism, the hold-open devices (230 volt) and if necessary additional devices.

Fire alarm systems

Fire alarm systems are devices, which automatically process the signals of the fire detectors and transfer them.

Parts of a fire alarm system can be used as a release mechanism.

Alarm system group

An alarm system group is the sum of fire detectors, for which an own indication mechanism is provided within the display for signals and errors.

The alarm system group can also consist of only one detector.

Door closers

Door closers are devices, which are made for closing movable closures, if needed also in the case of the breakdown of the energy supply.

Door closers

Hold-open devices

Regulations

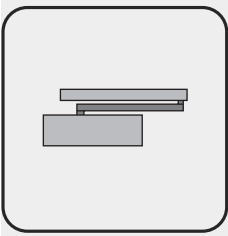

Final inspection

Following a ready to use installation of a hold-open device on the site of use, the faultless function and the installation according to regulations has to be assessed by a final inspection. This inspection has to be indicated by the manufacturer of the release and hold-open devices. It has to be arranged by the user.

The final inspection has to be carried out by qualified employees of the manufacturer of the release device and the hold-open devices, of authorised specialists or employees of a named test centre.

The final inspection has to cover at least the following services:

- The installed hold-open devices need to match the official approval certificates.
- The labeling of the installed devices need to match the labeling in the official approval certificates.
- The coaction of all devices has to be tested, according to the official approval certificate, by simulating the function-triggering fire parameters as well as a testing of the functions by hand.
- It has to be tested whether the self-closing function is released if the hold-open device fails its function (e.g. by failing of a detector due to a blackout).

If the final inspection has been successfully ended, a sign, size 105 mm x 52 mm, which has to be provided by the manufacturer of the hold-open device has to be permanently attached to the wall. On the sign it should say:

Hold-open device

Final inspection by ... (company logo as well as month and year of the final inspection)

An attestation of the successful final inspection has to be handed out to the operator, who has to preserve it.

Periodical inspections

The operator has to assure the functionality of the hold-open device at all times, the faultless function has to be checked at least once a month.

Furthermore the operator, or a hired specialist, is bound to assure a faultless coaction of all devices as well as an inspection of the function once a year, as long as no shorter period is given by the official approval certificate.

These inspections have to be carried out by a specialist or trained personnel.

The range, outcome and date of the periodical inspection have to be recorded and preserved by the operator.

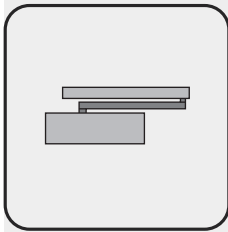

Door closers

14.8

Hold-open devices

The use of fire detection devices

Installation of fire detectors

Fire detection devices, which also activate upon smoke or temperature raises, can be installed in various areas.

In order to determine the number of necessary detectors it is assumed that one detector covers a surrounding range of 2,0 m. If the clear opening exceeds 4,0 m an additional fire detector or an additional pair of detectors has to be installed in order to cover the whole width of the clear opening.

As a rule a ceiling-mounted detector per side - a pair of detectors - has to be installed, additionally at least one transom-mounted detector has to be installed on one side of the lintel.

If the lower edge of the ceiling is not more than 1,0 m above the top edge of the clear opening which needs to be protected, no transom-mounted detector has to be installed. If the clear opening is not wider than 3,0 m and it is closed by a door, it is sufficient to install a transom-mounted detector.

If „ceiling-mounted detectors“ are required, they need to be installed directly underneath the lower edge of the ceiling, above the clear wall opening. The horizontal distance of the detectors from the wall, in which the wall opening is located, has to be at least 0,5 m and must not be more than 2,5 m.

If a „transom-mounted detector“ is required, it needs to be installed directly underneath the lower edge of the ceiling, above the clear wall opening not more than 0,1 m above the lower lintel edge.

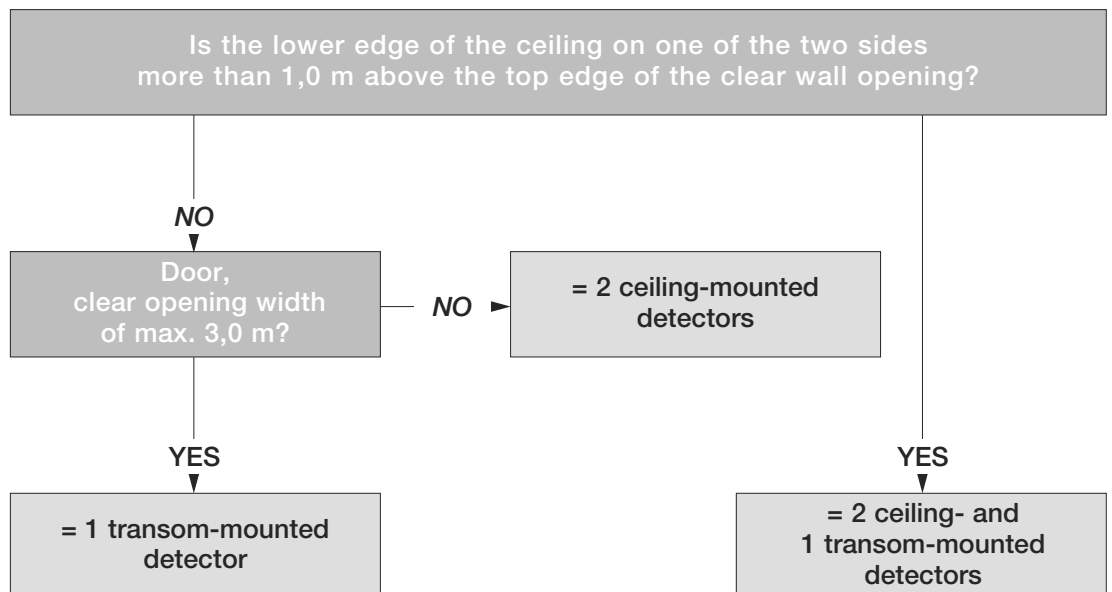

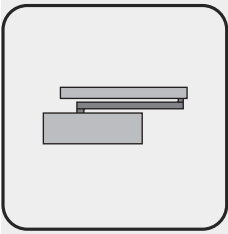

Door closers

14.8

Hold-open devices

The use of fire detection devices

Transom height < 1 m

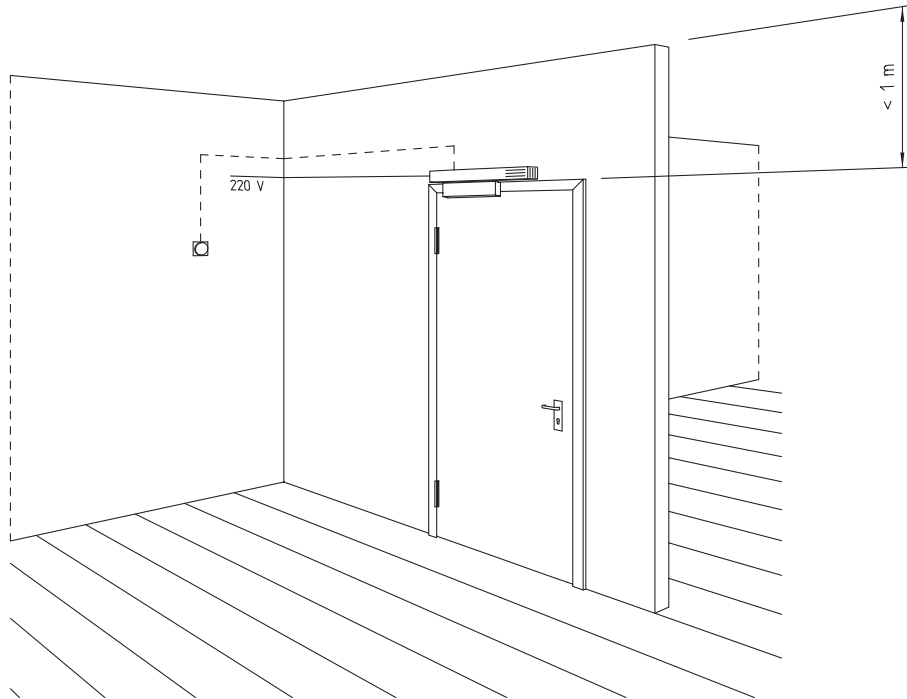

Transom height ≥ 1 m

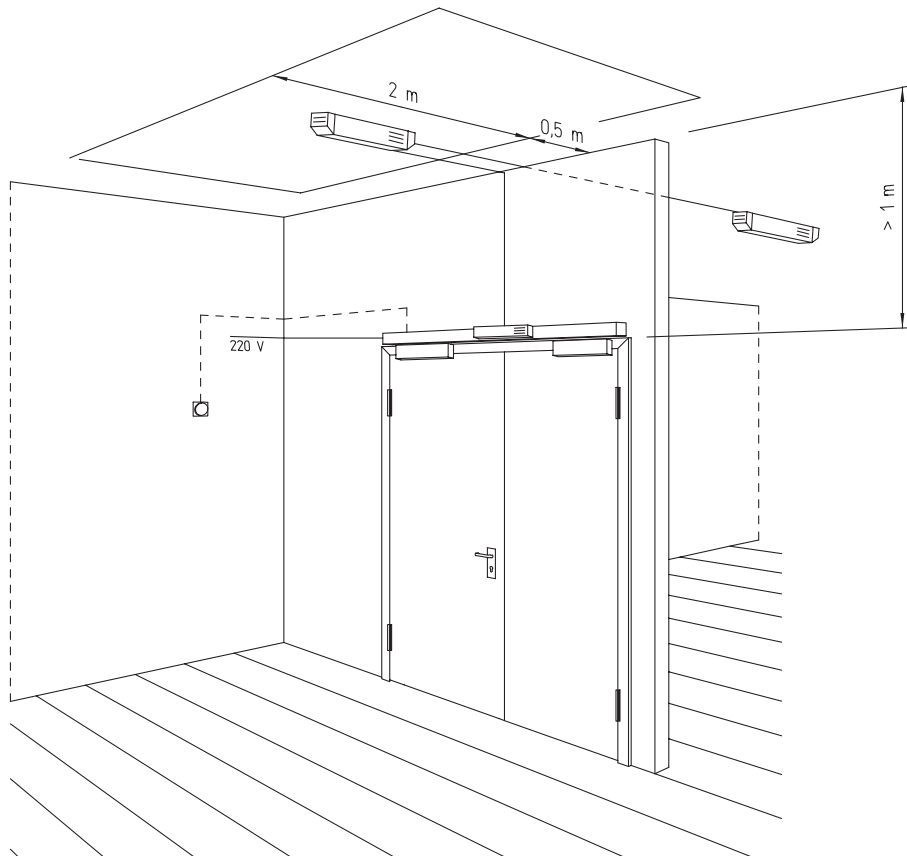

Wooden special doors

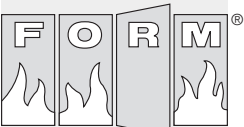

Schörghuber