

Handles

Content

	Page
13.1 General information	994 - 995
13.2 DIN 18255, DIN 18257 and DIN 18273	996 - 997
13.3 Handle configurations	998 - 1000
13.4 Escape door systems DIN EN 179, 1125	1001 - 1002

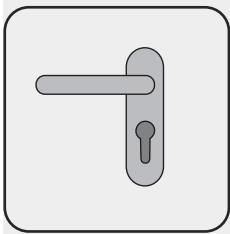

Handles

General information

Configurations

Function

A door is operated by a lever or knob, which is directly connected to the lock by spindle and follower. By pushing the lever down and so retracting the latch, the door can be opened by hand. Among its main function to open and close doors, the handle set, in combination with the hinges, turned out to be more and more important in the means of design for the private and public construction sector in recent years. Today, depending on the taste of the customer, handle sets are available in simple design to the point of eccentric creations of famous designers and architects.

Technical terms

Terms, dimensions and requirements of door handles are defined by DIN 18255, 18273 and 18257. In the following drawing the single components and parts of a handle set are illustrated.

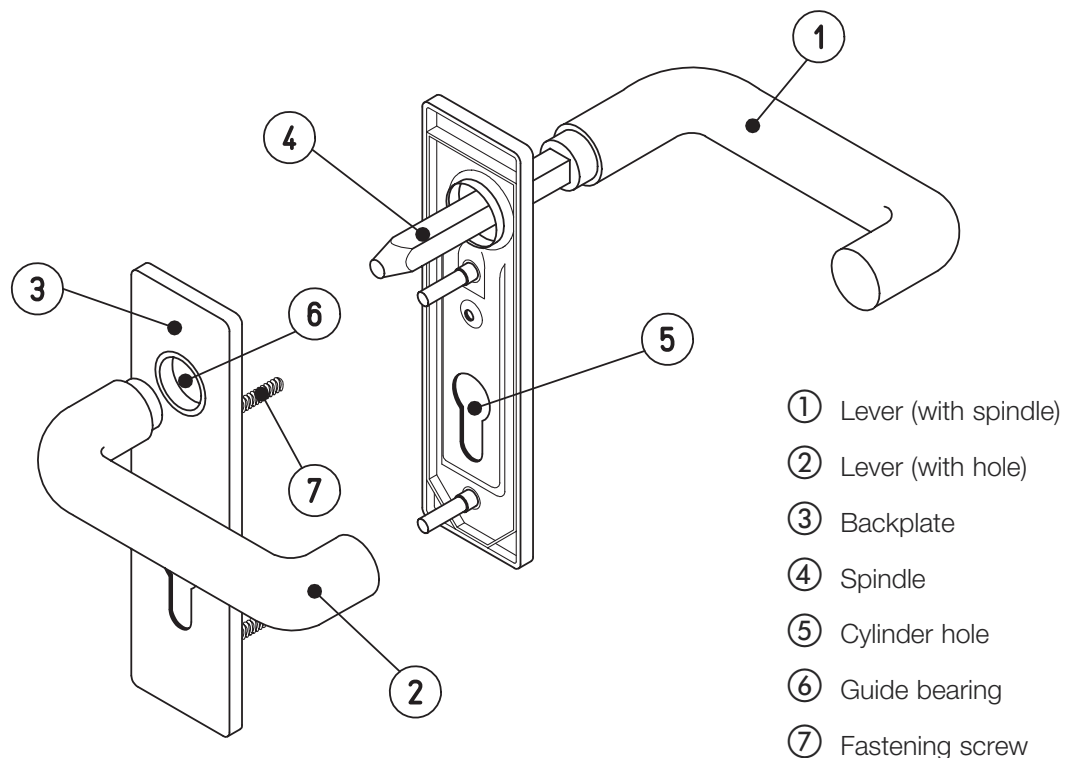

Handles, backplates and rosettes

Terms, dimensions and requirements are defined by DIN standards. Regarding the frequency of use of heavy-duty doors, e.g. in public buildings, administrations, hospitals, schools and universities, banks and demanding domestic building projects, handle sets are subject to long-term durability and fire protection testings, depending on the requirements and functions.

Using manufacturer specific constructions, concerning the guide bearing of the handles, it is assured that frequently used doors are able to absorb the energies during the opening and closing operations. In order to assure a long service life an installation according to the manufacturer directions is recommended.

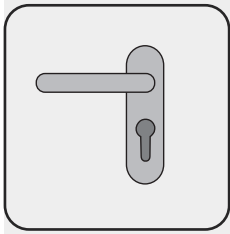

Handles

General information

Configurations

Height of the handles

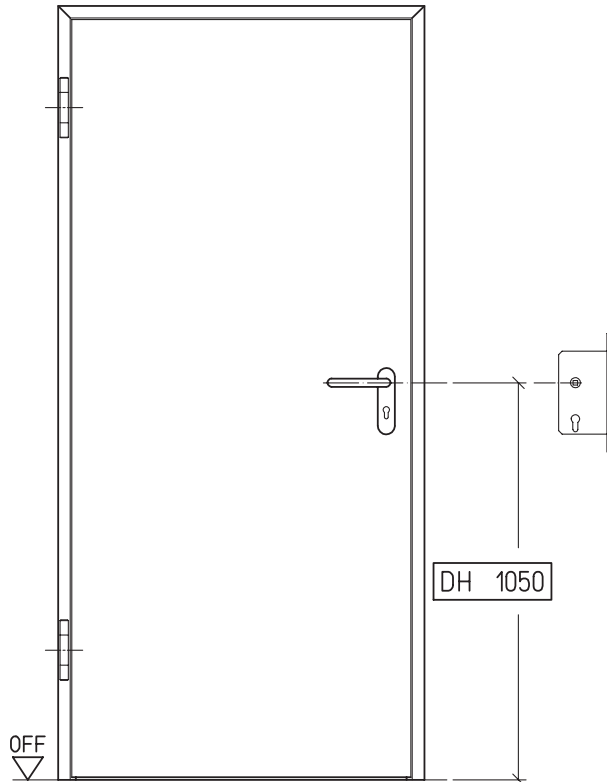

The height of the door handles (DH) is, according to DIN 18101, 1050 mm measured from the surface of the finished floor (OFF).

Differing heights are possible. Also for Fire- and Smoke-Protection-Doors the height of the handles can vary from 850 mm to 1250 mm.

The desired height of the handles (measured from the lower frame rebate) for 4-sided frames and especially for flaps has to be indicated.

Shape, material and surface

Door handle sets are described according to their cross-section, as for example round- or oval-shaped handles, but also according to their geometrical shapes, e.g. as U-shaped, L-shaped, flat-shaped, or described as semicircular shaped etc. Other handles are named after their production site e.g. Bauhaus-Handles or after their designers. Usually the various handle shapes can be combined with backplates, such as short backplate, long backplate or rectangular backplates of any kind of shape as well as with rosettes.

The appearance of a handle set is furthermore determined by the choice of material and the surface finish. Besides aluminium and plastic material as well as stainless steel and brass handle sets, also combinations of the materials metal/wood and metal/plastic material are possible. Aluminium handles can be coated with various eloxal colourings, stainless steel handles are available either matt or polished. Plastic material handles are available in various colourings.

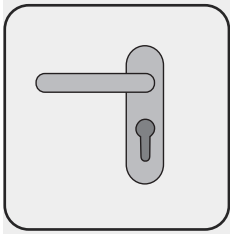

Handles

According to DIN 18255

Terms and requirements

Knob-lever set

Differing from panic function, for example apartment entrance doors can be equipped with a door knob on the outside. For this purpose a lock with panic function E, with which it is possible to retract the latch by turning the key, is necessary, as well as a knob-lever handle set.

Handle set for inactive leafs

In case that the inactive leaf of 2-leaf door sets should be equipped with a handle set, the installation of a so called handle set for inactive leafs in combination with a shot-bolt lock is necessary. This handle set, also known as one-sided handle set, describes a handle set with spindle, backplate or rosette as well as a counter blind backplate or blind rosette.

Due to the fact that this handle set is usually just necessary for 2-leaf door sets with full panic function (panic function on both leafs), Schörghuber special doors are by default not equipped with a one-sided handle set, but with a concealed shot-bolt lock. In this case, the opening of the inactive leaf can only take place, if the active leaf is opened and by operating a retractable lever in the door leaf edge. Alternatively also an inactive leaf bolting, type DORMA HZ, can be used.

Panic handle set

Doors in escape and rescue routes are equipped with panic function. The installation of these handle sets, usually called panic handles, is only effective, if combined with panic locks. Constructively, handles are differentiated between lever/lever sets (function B, C or D) with split spindle and knob-lever sets (function E) with one-sided fixed knob.

If equipped with panic function the door can be either equipped with a lever/lever set respectively knob-lever set, or also with an approved panic crossbar/push crossbar set on the push side, or on pull side with a one-sided fixed knob or a handle set.

Sports hall handles (flush)

According to special regulations regarding the configuration of sports facilities, doors have to be equipped with flush or just slightly projecting handles. Thereby the risk of injury should be precluded.

The installation of such a door handle set is also recommended for other areas, such as multi-purpose halls or for fixed doors in wall recesses, where the door handle should not project into the hallway respectively the escape route.

More details about the various handle set configurations can be found on the following pages.

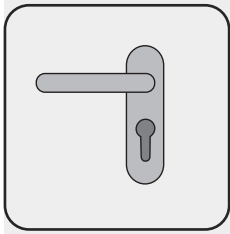

Handles

13.2

According to DIN 18257 and DIN 18273

Terms and requirements

Fire protection handle sets

Handle sets according to DIN 18273 are part of Fire- and Smoke-Protection-Door sets and therefore underlie the requirements of DIN 4102 part 5 and part 18. They have to undergo, just as functional doors, long-term durability and fire protection testings. Fire protection handles (Fire-Protection handles) need to be equipped with a square-cut spindle, diameter 9 mm. Handle sets made of materials with a melting point ≤ 1000 °C has to contain a steel core which is connected with the spindle and which extends 80 mm into the lever.

Fire protection handles for Fire- and Smoke-Protection-Doors are part of the approval respectively the test certificate and therefore need to be included in the delivery set of the door manufacturer. They can be delivered either as lever/lever or as lever/fixed knob handle set. Schörghuber Fire- and Smoke-Protection-Doors are by default equipped with a plastic material handle set in U-shape (lever/lever) with short backplate.

Security fittings

Burglar-Protection-Doors need to be equipped with solid security fittings in different resistance classes according to DIN 18257. According to the door function WK 2 or WK 3 adequate security fittings in the resistance classes ES 1 or ES 2 need to be used. Due to their construction security fittings hinder the forcibly twisting off of the profile cylinder and therefore a direct attack on the lock area.

In order to successfully hinder a pulling out of the profile cylinder, many security fittings are equipped with a pull protection. This cylinder faceplate (ZA), made of especially hardened metal should additionally prevent attacking respectively drilling of the cylinder.

For Burglar-Protection-Doors with a test certificate according to DIN V ENV 1627 an approved security lever/knob set has to be used.

One-sided fixed knob

Standard (ES 2)

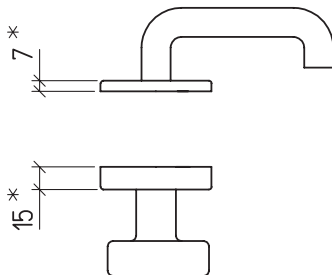

* Depending on the model

Handles

Configuration versions

Handles and backplate forms

Standard U-shape
Short backplate

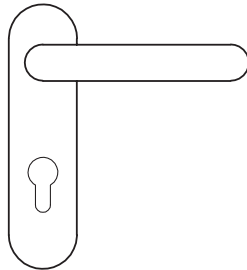

L-shape
Short backplate

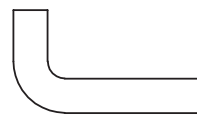
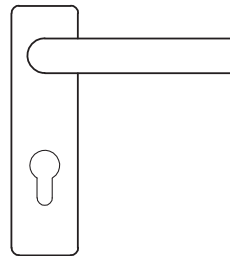

U-shape
Long backplate

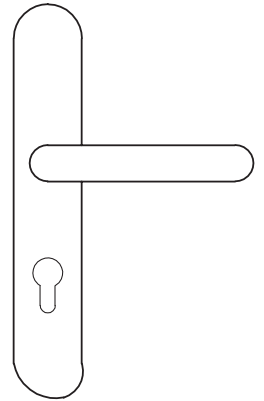

Special-shape
Rosette



Semicircular-shape
Rectangular backplate

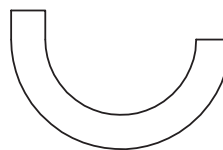
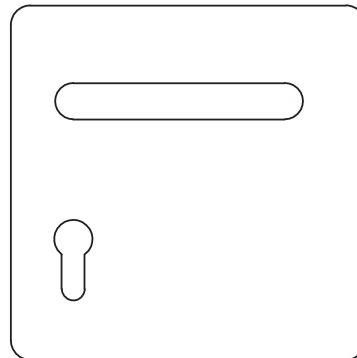

Knob-lever set

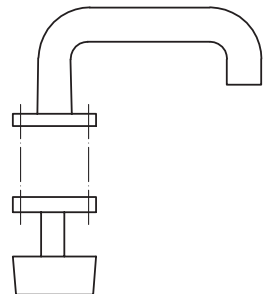

Wooden special doors

The displayed lever and backplate shapes show possible combinations which are available in different configurations according to the manufacturer.

For handle configurations with rectangular backplate in combination with doors and vision panels a minimum frieze width of 240 mm is necessary.

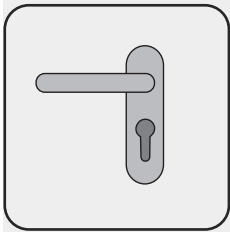

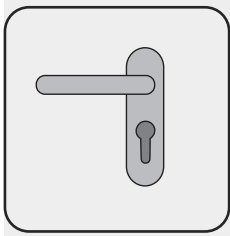

Handles

Configuration versions

Sports hall handles (flush)

Sports hall handles (flush)

According to special regulations regarding the configuration of sports facilities, doors have to be equipped with flush or just slightly projecting handles. Thereby the risk of injury should be precluded.

The installation of such a door handle set is also recommended for other areas, such as multi-purpose halls or for secured doors in wall recesses, where the door handle should not extend into the hallway respectively the escape route.

FSB 794*

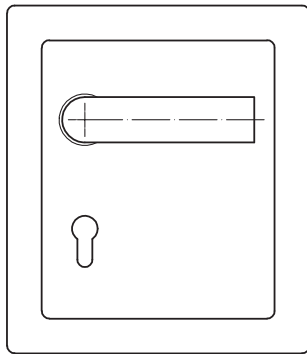

- 7940 Short backplate
- 7941 Rosettes
- 7942 Rosettes on the inactive leaf



Can be combined with all FSB handle sets

VIELER 544

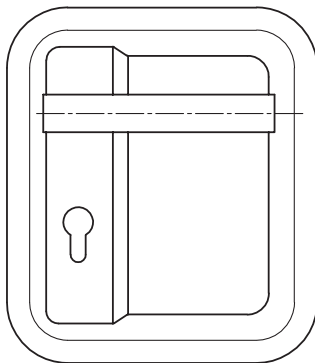

By default in combination with Vieler 522. ... with short backplate

Door type / Door leaf thickness	Edge geometry	Flush handle on one side		Flush handle on both sides	
		Pull side	Push side		
Heavy-duty	TD 42-1	Rebated	FSB Vieler		
		Unrebated	Vieler	Vieler	Vieler
	TD 42-2		On request		On request
	TD 50-1	Rebated	FSB Vieler	Vieler	Vieler
		Unrebated	FSB Vieler	Vieler	Vieler
		Unrebated with jamb rebate		FSB Vieler	
	TD 50-2	Meeting stiles standard rabbet ledge	FSB Vieler	Vieler	Vieler
	TD 70-1	Rebated	FSB Vieler	FSB Vieler	FSB Vieler
		Unrebated with jamb rebate	FSB Vieler	FSB Vieler	FSB Vieler
		Rebated with jamb rebate	On request		On request
		Unrebated with double-jamb rebate	On request		On request
	TD 70-2	Meeting stiles single rebate	FSB Vieler	FSB Vieler	FSB Vieler
Meeting stiles double-rebated		FSB Vieler	FSB Vieler	FSB Vieler	
T 30	TD 50-1	Rebated	FSB / Vieler	Vieler	Vieler
		Unrebated	FSB / Vieler	Vieler	Vieler
		Unrebated with jamb rebate		FSB Vieler	
	TD 50-2	Meeting stiles standard rabbet ledge	FSB Vieler	Vieler	Vieler
	TD 70-1	Rebated	FSB Vieler	FSB Vieler	FSB Vieler
		Unrebated with jamb rebate	FSB Vieler	FSB Vieler	FSB Vieler
		Rebated with jamb rebate	On request		On request
		Unrebated with double-jamb rebate	On request		On request
	TD 70-2	Meeting stiles single rebate	FSB Vieler	FSB Vieler	FSB Vieler
		Meeting stiles double rebate	FSB Vieler	FSB Vieler	FSB Vieler
T 90	TD 70-1	Rebated	FSB / Vieler	FSB / Vieler	
		Unrebated with jamb rebate	FSB Vieler	FSB Vieler	
	TD 70-2	Meeting stiles single rebate	FSB Vieler	FSB Vieler	
		Meeting stiles double rebate	FSB Vieler	FSB Vieler	

Note:

If sports hall handles (flush) are used, locks with a backset of 80 mm or more have to be used. Additional solutions can be realised by using doors with additional wood panelings.

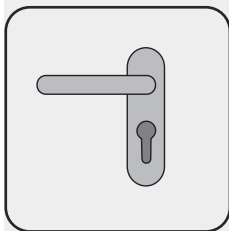

Configuration versions

Code card lock systems

Mechanical and electronic code card systems

Due to innovative technologies in the area of door fittings more and more new locking systems are developed, which offer a great range of application areas.

Concerning the operation, non-contact, mechanically or electrically functioning systems with magnetic card, coded keys or other data mediums are offered by various manufacturers. The advantages of these systems can predominantly be found in the area of hotels and private properties, whereas the function of common lock cylinders is replaced by programmable cards or data mediums. Authorisations and user-defined hierarchies can be arbitrarily changed, therefore a static locking system does not exist anymore.

In order to be used in combination with fire and smoke protection function these systems need a verification of suitability according to DIN 18273 (official test certificate by the building authorities). Furthermore a long-term durability and fire protection testing according to DIN 4102, part 5 and part 18 has to be verified.

Systems for conventional locks according to DIN are mounted instead of the common fittings. The fittings also match, if the door is equipped with a standard DIN-lock, a self-bolting lock or a lock with multiple bolting device.

The following listing shows approved FS / RS code card lock systems.

Manufacturer	Product name	FS / RS	WK 2/3
Burg Wächter	TSM 500 F/TSM 510 F	Yes	No
Compart	CL 2000	Yes	No
ECO (identisch Compart)	Compart CL 2000	Yes	No
eff eff (ASSA ABLOY)	ANYKEY	Yes	Yes
Häfele SPHINX	Dialock	Yes	No
Häfele SPHINX	DT/FH, DT/ProFH, DTSH FH	Yes	No
HEWI	Electronic lock system	Yes	Yes
HEWI	Electronic compact lock system	Yes	No
HEWI	Wall or door mounted code card reader	Yes	No
HEWI (identical with Schulte S. VARIFLEX)	Magnetic card system	Yes	No
KABA	Elologic lock	Yes	No
Messerschmitt	Key Card System	Yes	No
NORMBAU	PegaSys	Yes	No
ONITY	HT24-B, HT28-B	Yes	No
Schulte Schlagbaum	VARIFLEX	Yes	No
Schulte Schlagbaum	VARIFree	Yes	No
TimeLox	TimeLox T90	Yes	No
VingCard	VC2100/3000 EURO	Yes	No
VingCard	da vinci	Yes	No
VingCard	signatur	Yes	No
Additional models on request			

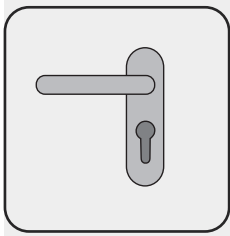

Handles

Escape door systems

Regulations

Escape door systems für Europa

Since the 1st of April 2003 new, standardised norms for escape doors apply for the whole of Europe. An essential innovation: lock, fittings and mounting accessories are tested combined and are only allowed to be sold and used as a set.

The new EU-standards divide escape door systems according to their area of application into emergency exits and panic closures.

Emergency exits

Emergency exits according to DIN EN 179 are designed for buildings without foot traffic and whose visitors and users know the function of the escape doors.

The standard specifies a vertically on the lever operating test force of at most 70 N, at which the bolting elements of the door should unlock and the door should open automatically.

The handle sets can be ordered as lever/lever or lever/knob sets. A continuous screw connection is compulsory. The mounting accessories are also part of the certified fittings. In order to prevent injuries the basic dimensions of the handle set are predetermined. The open end of the door lever has to be configured in order to face the door leaf surface.

Handle set for emergency exits

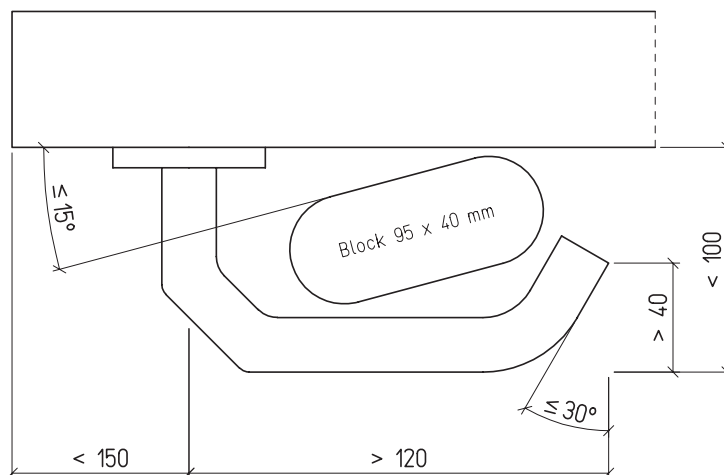

Maximum release force

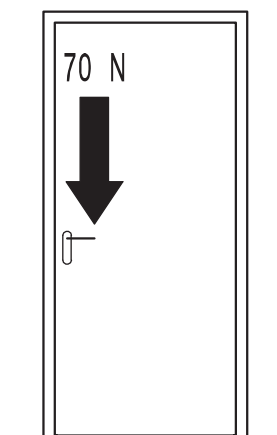

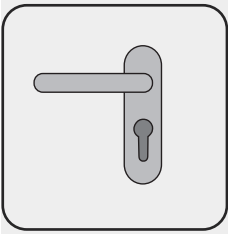

Handles

Escape door systems

Regulations

Panic doors

Panic doors according to DIN EN 1125 are designed for public buildings whose visitors and users do not know the function of the escape doors and who need to be able to use the emergency exits without being instructed. This applies for example for hospitals, schools, public administrations, airports and shopping centres.

The release forces for panic doors are regulated as well. In two different procedures the locking system is tested, on the one hand the door set is tested without initial load. With an operating force of at most 80 N the door should open automatically. During the second procedure an initial force of 1000 N affects the door leaf. Hereby the operating force should not exceed 220 N.

On the escape side of panic doors crossbar handles or push crossbars, which extend across the whole width of the door set, are compulsory. On the outside according lever, knob or blind backplates have to be installed. The handles on the outside and the mounting accessories are also a certified part of the fittings.

Panic crossbar

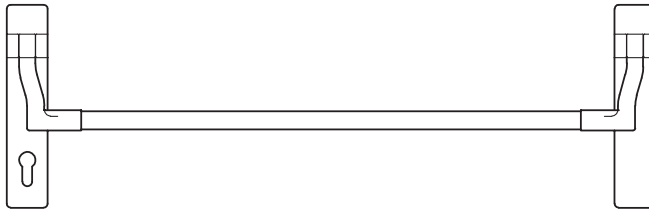

Push crossbar

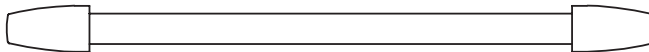

Maximum operating force

